



Chapter 242

Case Study for Modernization of the Natal/RN Giga Metropole Network, in line with Recommendation ITU-T G.989 (NG-PON2)

  <https://doi.org/10.56238/devopinterscie-242>

Victor Fassanaro Cortez de Carvalho

Electrical Engineer

Institution: Federal University of Rio Grande do Norte
Av. Senador Salgado Filho, nº 3000 - CEP 59078-900
UFRN-Campus Universitário Lagoa Nova - Centro de
Tecnologia -Natal - RN- Brazil
E-mail: vitorfassanaro@gmail.com

Gutemberg Soares da Silva

Ph.D. in Electrical and Computer Engineering from UFRN
Institution: Federal University of Rio Grande do Norte
Av. Senador Salgado Filho, nº 3000 - CEP 59078-900
UFRN-Campus Universitário Lagoa Nova - Centro de
Tecnologia Natal - RN- Brazil

Fred Sizenando Rossiter Pinheiro

Ph.D. in Health Sciences from UFRN
Institution: Federal University of Rio Grande do Norte
Av. Senador Salgado Filho, nº 3000 - CEP 59078-900
UFRN-Campus Universitário Lagoa Nova - Centro de
Tecnologia -Natal - RN- Brazil
E-mail: fredrossiter@uol.com.br

ABSTRACT

In recent years, the importance of improving the quality of internet services in public institutions has grown, especially those that work in the areas of Education, Health, and Safety, constituting an important tool for the social, economic, and cultural development of society. In this context, the National

Teaching and Research Network–RNP, through the Community Teaching and Research Networks–REDECOMEP and its Points of Presence-PoPs, which operate on a high-speed network in the metropolitan region of Natal/RN, with infrastructure based on fiber optic network technology, interconnecting several public and private institutions, aiming to provide access to various services. The PoP-RN, with its Giga Metr pole and Giga Natal networks, based on G-PON (Gigabit Passive Optical Network) technology, serves public schools, universities, hospitals, UBS/UPAS, police stations, with a network extension of over 260 km. The work described in this article performs a structural and technological evaluation of this network and develops a case study to evaluate possible options to improve the provision of services to users, through modernization directed to more current standards, being chosen for analysis of the NG-PON2, governed by ITU-T G.989 recommendation which provides for a fiber capacity of 40 Gbit/s, exploiting multiple wavelengths in dense wavelength division multiplexing channel spacing and tunable transceiver technology at user terminals.

Keywords: Internet, Passive Optical Networks, G-PON, NG-PON2.

1 INTRODUCTION

The Community Networks of Ensino e Presearcha-REDECOMEP, inaugurated in 2005, uses fiber optic technology to provide internet access to users from various urban centers in the country, through the Points of Presence-PoPs [1]. REDECOMEP was implemented in the age of Natal, with the denomination of Rede Giga Natal, which is coordinated by the National Network of Education and Research-RNP and operated by PoP-RN. Its main objective is the execution and maintenance of a high-speed internet network in the metropolitan Region M of the Capital Potiguar, with infrastructure based on the technology of fiber

optic networks, interconnecting various public and private institutions, especially those focused on teaching and research [2].

The Giga Metr pole Network, which emerged from the expansion of the Giga Natal network, provides internet access to educational and research institutions, and public agencies at the federal, state, and municipal levels, in the areas of education, health, and safety. Using G-PON (*Gigabit Passive Optical Network*) technology, the network has a *backbone* of superior dimensions at 2,85 km in the metropolitan region of Natal [3].

The first recommendations of the G-PON standardization were published in 2003, called "S rie ITU-T G.984", which analogously to the *Broadband Passive Optical Network* - B-PON supports several different transmission rates, in which the most used are: 2,488 Gb/s, downstream; and, 1,244 Gb/s, in the *upstream* sense, which are shared by users of the same network [4].

This study aims to evaluate the characteristics and architecture of the passive fiber optic network technology called *Next Generation Passive Optical Network 2* – NG-PON2 [5] to plan the modernization of the provisioning of the Giga Metr pole network and improve the service made available to users of the PoP-RN network. NG-PON2 emerges as an extension of fiber optic network capabilities, which provides 40 Gb/s transmission in both downstream and *upstream directions*. To ensure interoperability with its predecessor networks, wavelengths from 1524 to 1540 nm were chosen for *upstream*; and 1596 to 1603 nm for *downstream* [6].

The methodology used to carry out the research was a literature review of the state of the art of PON network technologies, the collection, and analysis of information from the G-PON network housed in Pop-RN, the study of recommendation G989.1 of the ITU-T and the fieldwork developed in the PoP-RN.

The structure of this article is divided as follows: section 2 presents a bibliographic review with a brief explanation of basic concepts of passive optical networks, the G-PON standard, its purposes and use in PoP-RN; section 3 presents an overview of the latest generation of passive optical network (PON) technology standards, called *Next Generation Passive Optical Network 2*–NG-PON2, section 4 shows the fundamentals of strategic planning for the future of the Giga Metr pole Natal-RN network, with migration direction from the G-PON system to NG-PON2 in line with recommendation ITU-T G.989; and finally, section 5 addresses the main conclusions of the work.

2 THEORETICAL FRAMEWORK

2.1 PASSIVE OPTICAL NETWORKS

The PON (*Passive Optical Network*) network is a converged infrastructure that can carry several services such as conventional telephony, voice over IP, data, video, and/or telemetry, in which these services are converted and encapsulated in a single type of packet for transmission over fiber optics. This network is characterized by the absence of equipment of an active nature, which requires electrical power, between the place of service and the service provider. In addition, this type of network is based on CWDM

(*Coarse Wavelength Division Multiplexing*) technology, which uses different wavelengths, in two-way transmission, to carry out communication between the edge devices [7].

Defined by [6], a PON performs the connection through an *optical distribution* network (ODN), composed of fiber optic cables and optical *splitters*, together with the active elements located at the ends of the network, namely: OLT-Optical *Line Terminal*); and, Optical Network Units (UN-Optical Network Unit), or Optical Network Terminal (ONT-Optical *Network Terminal*).

According to [8] the Equipment Center (OC) acts as the starting point of the network, having as function to accommodate all the equipment of an active nature, which performs the transmission of information from the service provider, managing connections between optical terminals and facilitating the physical and logical connection of the active equipment of the network.

The power cord is integrated by several fibers that depart from the central office to the primary hub, also known as *the Fibre Concentration Point* (FCP), which is responsible for the distribution of the fibers from the power cord that depart from the CO in smaller capacity groups, so that there is greater flexibility in the distribution of light signals in the network. The FCP must be located in the vicinity of the users and from it is built the distribution network to serve the users [7]. Passive fiber optic networks are composed of several devices, ranging from active components such as OLT, UN, ONT, and optical transceivers; as well as passive components such as fiber optics, optical *splitters*, and general optical distributors (DGO), among others.

The OLT is located in the central office of the provider and its function is to coordinate all the communication carried out between it and the Unidades de Rede Óptica - ONU, and the Terminals de Optical Network - ONT connected to it and can supply more than a PON, simultaneously, and serve customers at distances of up to 20 km. Depending on the PON standard, each OLT can supply access to 32, 64, or 128 users per network, with the bandwidths 155Mb/s, 622Mb/s, 1.25Gb/s and 2.5Gb/s, which are among the most common on the market [8].

The active elements located closer to or in the user himself are called ONT and ONU, to which they are greatly reduced. The main one is that the ONT is a device that is located in the user's premises, while the UN is used in external environments, in cabinets that house equipment of the same nature, close to the users' premises [7]. This equipment can supply various types of services, such as internet access in the most varied values of bandwidth, telephone connections, and video in digital and analog formats.

Another device that allows connection to fiber optic networks is the optical transceiver, also known as a *transceiver*, which acts as a receiver and transmitter in a single device. There are currently seven types of *transceivers* used in optical networks. Widely used in optical fiber networks, we can mention the GBIC (*Gigabit Interface Converter*) transceivers, and their successor, the SFP (*Small Form-Factor Pluggable*). They provide connections of equipment, such as computers and switches, to the optical network and later to OLT [8].

The main component of the distribution network, the optical fiber, uses the phenomenon of total internal reflection to transport the light signal between the active equipment of the network. An integral component of ODN, the Passive Optical Splitter, the optical *splitter* has the function of dividing the signal coming from the OLT in the downstream direction, or combining the signals coming from the UNs or ONTs in the *upstream* direction. According to [8], *splitters* can be classified in three ways. First, we have it in a balanced (symmetrical) configuration. In this case, the signal coming from the OLT has its power equally between all outputs, which usually use ratios of divisions of 1:N or 2:N, where N is a power of 2, having 128 the maximum number of divisions supported. The second configuration of the *splitters* is known as unbalanced or asymmetrical, in this case, the signal power coming from the OLT is divided unevenly between the output ports of the splitter. The choice of this type of *splitter* is made according to the need to provide a greater amount of power to a given location of the network, to the detriment of another, due to greater distances or the number of users. Finally, there are *splitters* known as WDM filters, in PON networks that have the task of combining or separating the transmitted signals at the different wavelengths that are used in the network.

2.2 GPON – GIGABIT PASSIVE OPTICAL NETWORK

The GPON standardization, developed by the telecommunications standards sector of the ITU, marks the beginning of the second generation of networks in passive fiber optics GPON, being specified in the ITU-T G.984 series, which characterizes transmission and media systems, digital systems, and networks, being known as G.984 [9]. Recommendation ITU-T G.984.1 defines the general characteristics of G-PON systems, meaning that systems based on this recommendation must have transmission rates equal to or greater than 1.2 Gbps. Combinations of transmission rates are recommended: 1.2 Gbps for upstream and 2.4 Gbps for downstream, 2.4 Gbps for *upstream*, and 2.4 Gbps for *downstream*.

The distances that GPON networks can serve their users are known as physical, logical, and differential distances [8]. The logical distance, associated with the communication protocols between the OLT and the ON, is the maximum distance between any UN/ONT and the OLT, taking into account the limitations of the physical environment, which is 60 Km. The physical distance, related to the optical characteristics of the network, is defined by the physical components of the network and determines the maximum actual distance between the UN/ONT and the OLT. In this case, we have distances of 10 and 20 Km. When it comes to the differential distance, its maximum value is up to 20 Km, which is the longest distance between two ONU/ONT from the OLT. With the release of recommendation G.984.7, known as G-PON: *Long Reach* (G-PON long-range), taking into account a certain amount of signal attenuation it is possible to achieve maximum differential and physical distances of 40 and 60 km, respectively; Whereas maximum logical distance is still 60 Km. The G-PON uses the wavelengths of 1490 nm, for data transmission in the *downstream* direction, and 1310 nm, in the *upstream* direction.

The operation of the G-PON network occurs through communication between OLT and the UN, or ONT of the clients, through a topology of peer-to-peer communication, where the OLT sends information at a specific wavelength to all UNs and these through a TDMA (*Time-Division Multiple Access*) schemes, which may send or request information from OLT using a specific wavelength other than that used by OLT [7].

GPON networks must be able to support services that demand an average signal transfer delay of up to 1.5 milliseconds. This time is calculated from the T-V points identified in Figure 1.

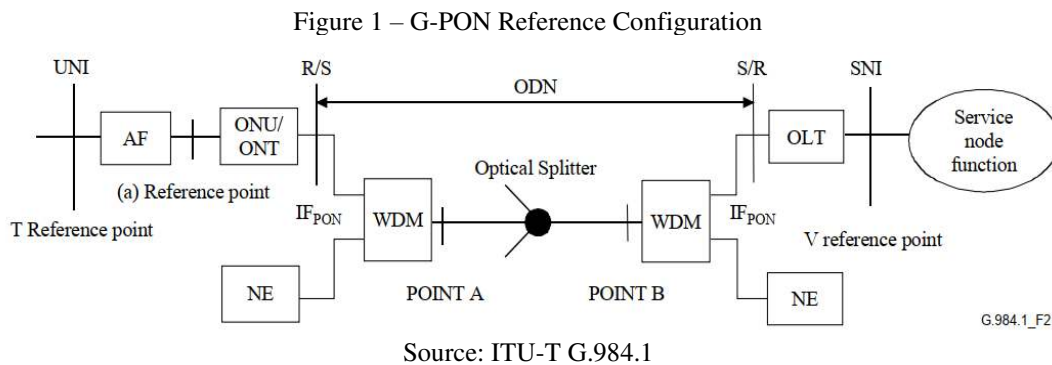

Other outstanding G-PON network characteristics are service capacity per network, which is defined by the maximum number of divisions (*split ratio*), which can be performed, and redundancy. The transmission convergence layer (*TC Layer*) should be designed for up to 128 divisions, considering the continuous technological evolutions in the optical modules of the time. The redundancy of the network, which even being optative, is considered important to increase confidence in the operation of the network in emergencies. The G.984.1 standard determines two forms of alternation between the main optical network and the redundancy network: automatic and forced exchange. The automatic exchange is activated in case of detection of problems, such as loss or degradation of signal, and loss of frames, among other problems; and, the forced exchange occurs when there is a need to perform activities, such as route forwarding, replacement of fiber stretches, among others. Figure 2 shows a network model that has redundancy.

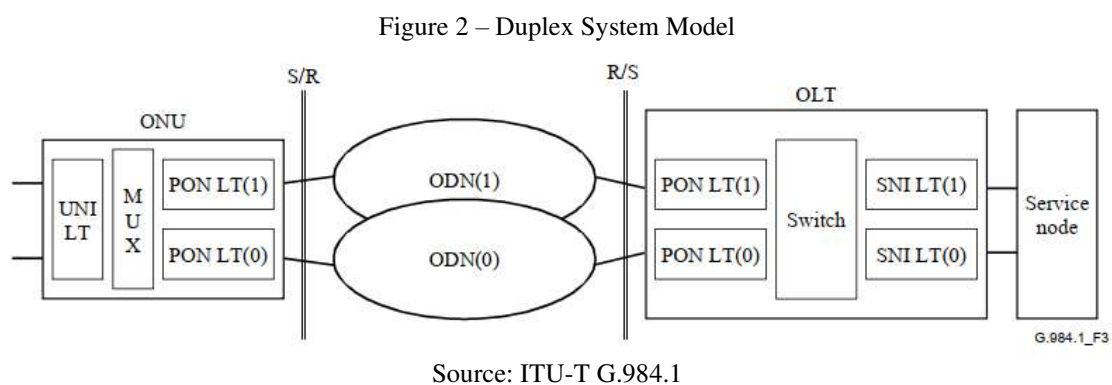

2.3 GIGA NATAL AND GIGA M ANDTRÓPOLE NETWORKS

The Giga Natal network is a high-speed metropolitan network that connects the main educational and research institutions in the region, contemplating in the initial version, the area of the Cage of Natal, connecting the Center for Gas Technology and Renewable Energies (CTGAS); Petrobras (Headquarters); the Nursing Sector (UFRN-Central Campus); the Department of Dentistry (DOD); Tower of TV University (TVU); Central Campus of the Federal Institute of Rio Grande do Norte (IFRN); Museu of UFRN; Naval Base; Center for Health Sciences (CCS-UFRN); PoP-RN itself. These points highlighted in Figure 3 are called d and Gigapops and are interconnected through fiber optic cables, using Metro Ethernet network technology.

Figure 3 – First stage of the GigaNatal Network

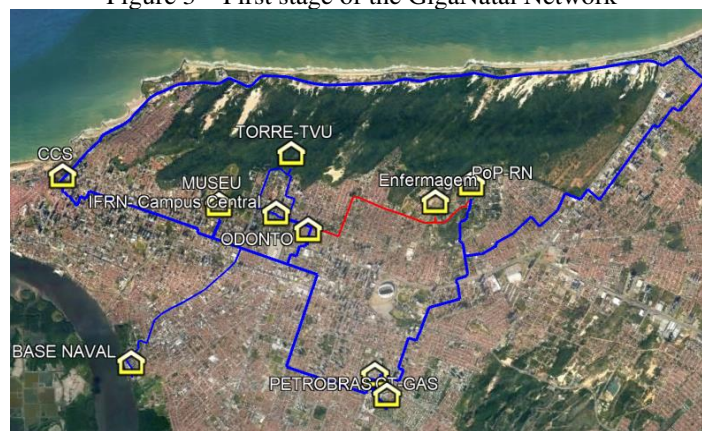

Source: PoP-RN [2]

In 2017 the network was expanded to serve other points within the metropolitan region of Natal, identified in Figure 4, including the cities of Parnamirim, Macaíba, São Gonçalo do Amarante, Vera Cruz, Monte Alegre, São José do Mipibu, Extremoz, and Ceará-Mirim. Subsequently, other Gigapops were added to the network, namely: the IFRN Campus in the North Zone, São Gonçalo do Amarante and Parnamirim; the Agricultural School of Jundiaí; the Camp us do Cerebral; three ERBs located in the cities of Extremoz, Ceará Mirim, and Vera Cruz; in addition to two other support points in Monte Alegre and São José do Mipibu.

Figure 4 – Expansion of the Giga Natal Network

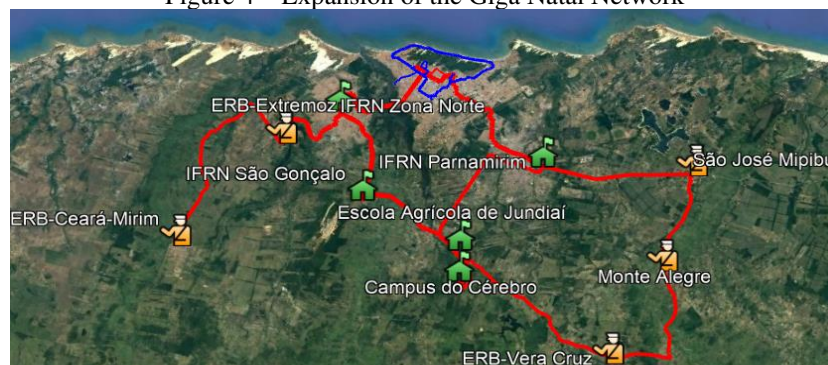

Source: PoP-RN [2]

From this structure was implemented the Giga Metre Opole Network using the Gigapops as support points for the attendance of about 346 public schools in this region, quantified in Table 1.

Table 1 - Summary table of the schools interconnected by the project.

Nature of Schools	Municipality	Quantity
State	Christmas	112
	Parnamirim	09
	Macaíba	12
	São Gonçalo do Amarante	03
	Total	136
Municipal	Christmas	132
	Parnamirim	58
	Macaíba	15
	São Gonçalo do Amarante	05
	Total	210
Grand Total		346

Source – IMD [3]

The PoP-RN network is bordered by six OLTs, of which 04 (four) are in the city of Natal, in the following locations: 01 (one) PoP-RN; 01 (one) IFRN North Zone; 01 (one) CTGAS and 01 (one) Museum; 01 (one) at the IFRN campus of Parnamirim; and the last one in Macaíba, at the Agricultural School of Jundiaí. Each OLT has on average three G-PON ports being used, and each port is designed to serve up to 32 schools. Splitting is always performed on two levels: first, a 1:4; and later another of 1:8. Figure 5 shows an example of the OLT in the PoP-RN Data Center of the network to serve 29 schools.

Figure 5 – OLT Assembly in the PoP-RN Data Center

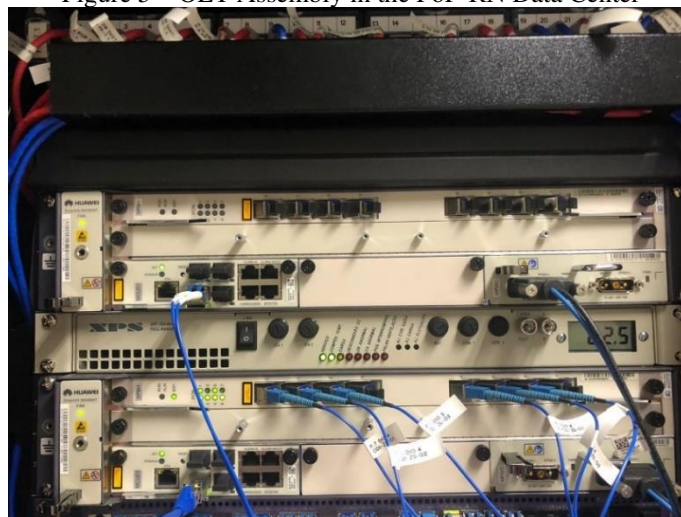

Source – PoP-RN [2]

The passive components determine the losses that occur during the path of the signal on the link [10]. For the correct functioning of a fiber optic link, it is necessary to ensure that signal loss standards are met with lower tolerances. In this way, the performance of a link is linked to a series of characteristics of the active and passive components that compose them. The active components determine both the amount of power that comes out of the transmitters, and the necessary amount of power that the receivers must

receive for the signal to be detected. The difference between the output power and the loss of the signal must be greater than the sensitivity of the receiver [8].

Considering the geographical spread of the schools served, as shown in Figure 6, the level of attenuation differs greatly between each of them. In this scenario, the worst case of power budget was recorded, contemplating the largest physical distance between OLT and UN, measuring a total of 17.27 km. For this evaluation, transmission levels and class B+ sensitivity are used, so it is necessary that the OLT and UN receivers, reach a signal level higher than -28 dBm and -27 dBm, respectively, and the maximum power level emitted by the two pieces of equipment is 5 dBm.

Figure 6 – Connection Diagram of one of the OLT ports in PoP-RN.

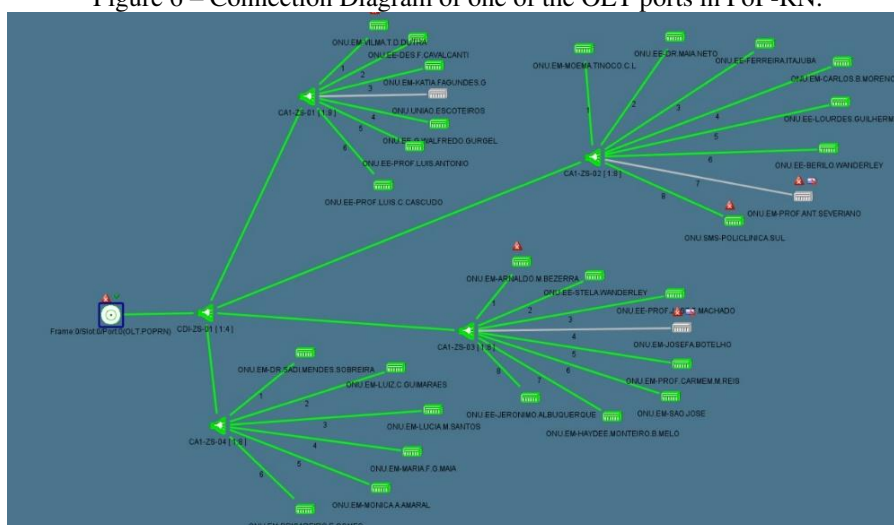

Source: PoP-RN [2]

For this evaluation are used transmission levels and sensitivity class B + are, so it is necessary that the receivers of OLT and UN, reach a signal level higher than -28 dBm and -27 dBm, respectively, and the maximum level of power emitted by the two equipment is 5 dBm.

It was verified the level of the power transmitted of 1.85 dB by the UN, and the power received by the OLT of -23.98 dBm, indicating a total path attenuation of 22.13 dBm, providing a certain margin of acceptance available, since the total power capacity of the UN has not yet been used and the received signal is above the level of -28 dBm; and the UN receiver measured a signal power of -19.32 dBm.

Figure 7 shows some examples of the power levels in the receivers of some other schools in the PoP-RN network. For schools the following equipment is available: 01 (one) PTO for fiber input, 01 (one) UN to provide access to the optical network, 01 (one) switch to provide access to computers, and 01 (one) rack for the storage of the aforementioned components.

Figure 7 – Power levels received in schools.

CED-PRE.ESC.LUIZ.C.CAS...		CED-MUL.PEDRO.D.SOUZA		EM-FABRICIO.G.PEDROZA		EM-JOSE.P.BORGES	
OK		OK		OK		OK	
Potência		Potência		Potência		Potência	
-13.89 dBm		-13.87 dBm		-14.93 dBm		-14.15 dBm	
Ativo	Status	Ativo	Status	Ativo	Status	Ativo	Status
ONU	UP	ONU	UP	ONU	UP	ONU	UP
		SWITCH	UP	SWITCH	UP	SWITCH	UP
		AP	UP	AP	UP	AP	UP

Source – PoP-RN [2]

3 NEXT-GENERATION PASSIVE OPTICAL NETWORK PHASE 2 – NG-PON2

NG-PON is divided into two phases: NG-PON1 and NG-PON2 [11]. NG-PON1 focuses on PON Technologies compliant with GPON standards as well as current ODN. NG-PON2 emerges as the next step in passive fiber optic networks. Initially formulated by network operators who are members of the FSAN (*Full Access Service Network*) consortium, this standardization/recommendation established the use of disruptive technologies in the PON network environment. For example, operating *wavelength* splitters, rather than power splitters, are used in G-PON networks. Considering the investments that network operators have already made in their infrastructures, it was necessary to develop a standard seeking compatibility with the ODNs and existing systems. Thus, NG-PON2 was developed considering two precursor recommendations, G-PON and XG-PON (*10-Gigabit Passive Optical Network*) [12].

The wavelength ranges for NG-PON2 were selected because of the best compatibility with the services already implemented in the networks that operate today in the market, such as G-PON, XG-PON, and RF video. In addition, work with the already implemented coexistence wavelength multiplexers, ease of filtering, availability of components in the C and L optical bands, and minimizing Raman effects [12].

Recommendation G.989.1-40-Gigabit-capable *passive optical networks: General requirements*. [13] NG-PON2 networks must be able to use architectures that support channels with multiple wavelengths, using *Time Wavelength Division Multiplexing* (TWDM) technology [14]. For transmission, the nominal rates per channel are specified: 10 Gbits/s downstream and 10 Gbits/s upstream; 10 Gbits/s downstream and 2.5 Gbits/s upstream and 2.5 Gbits/s downstream and 2.5 Gbits/s upstream.

Using only passive components in the ODN, the networks in this standard can meet points at a distance of at least 40 Km, with a maximum differential distance of 40 km, the latter can be configured as 20 or 40 km, in addition to meeting split rates of 1:256. The structure of a network in NG-PON2 meets several functionalities related to the previous systems. Figure 8 shows the network structure, in which the coexistence of several systems occurs. In it we can observe the CEx, an important component for the simultaneous action of all networks, which aims to establish the connection of several signals from different sources in a single fiber, performing the multiplexing and demultiplexing of services arising from the OLTs

of the NG-PON2, XG-PON, and G-PON network, along with RF video and monitoring service, via the optical time-domain reflectometer (OTDR).

Figure 8 – Reference Architecture for NG-PON2 System

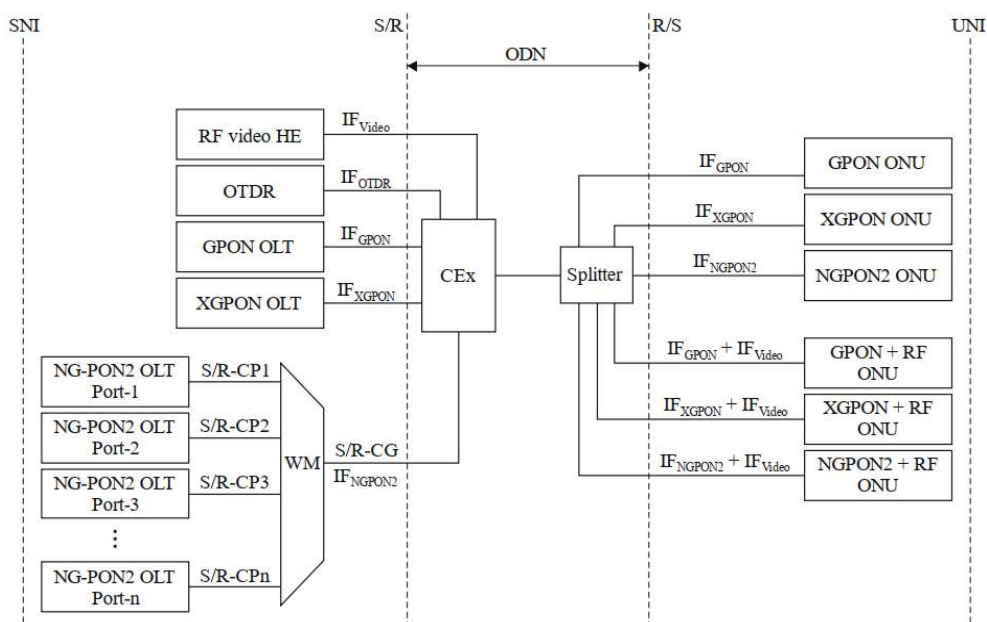

Source: ITU-T G.989.1

Table 3 below highlights comparative aspects and the G-PON and NG-PON2.

Table 3 – Comparison between G-PON and NG-PON2

	G-PON	NG-PON2
Maximum Transmission Rate per Channel	2,488 Gb/s Symmetrical	10 Gb/s Symmetrical
Number of Channel Pairs	1	4-8
Split Ratio	1:128	1:256
Maximum Physical Distance of Care	20 km	40 Km

Source: Own Authorship

Security is an important aspect in passive fiber optic networks, and in the case of NG-PON2, analogous to G-PON, *downstream* channels are broadcast so that any UN operating at a certain wavelength will receive data packets even if it is not the recipient of the request. Four types of threats must be combated by NG-PON2 systems are determined by the ITU-T in G.989.3 [15]:

I) Since all *downstream* transmission is broadcast to all UN, malicious users may be able to exchange or reprogram a UN, capable of intercepting information intended for all other users;

II) Since any UN can generate *upstream* traffic to OLT connected to the distribution network, malicious users may try to appear to be another UN to take advantage of services that do not belong to them;

III) A network attack, in which someone can connect a device through the network infrastructure such as street cabinets, doors, or spare cables, and can act as an OLT or UN to perform information interception;

IV) Malicious users can write packets already sent and can relay those packets back to PON or conduct attacks.

To prevent or mitigate the occurrence of these threats, important aspects of network security are employed, such as UN authentication connected to the network, and the use of encryption in the data that is transported, among other functionalities linked to these two aspects.

4 FUNDAMENTALS OF PLANNING THE MIGRATION OF THE G-PON SYSTEM TO NG-PON2

Migration to the NG-PON2 system by service providers can be analyzed from network scenarios. Two main scenarios are foreseen, Greenfield and *Brownfield*. The first scenario is characterized by the absence of a PON in operation using any technology to inform the NG-PON2, such as G-PON, XG-PON, GE-PON, and 10G-PON. In its way, NG-PON2 is used to meet a new demand of users or replace networks deployed with metal cables. The second scenario is marked by the existence of a PON, in which certain users present a growing demand for bandwidth, which makes them candidates to be transferred from PON in operation to NG-PON2, with the need for coexistence between two or more passive fiber optic network technologies acting on the same ODN [16]

Three migration paths are determined by the ITU-T in its recommendation G.989.1, which differ and flexibility: direct, flexible, and comprehensive. The first occurs when the migration is performed from G-PON to XG-PON, and later to NG-PON2. In this way, complete migration between the predecessor technologies is necessary to initialize the migration to NG-PON2, with the possibility of reusing the wavelengths of G-PON. The second is marked by the direct migration of G-PON to NG-PON2, with the need only for coexistence between the two standardizations. The third is characterized by the coexistence of three standards, having great flexibility of service to users, although it involves the greatest challenge of implementation because it is the possibility of being in simultaneous operation of three different technologies in the same ODN.

NG-PON2's wavelength plane coexists with the wavelength planes of previous PON systems such as G-PON, XG-PON1, and radio frequency (RF) video overlay, enabling the reuse of existing infrastructures.

Analyzing the current situation of the network under study, it can be verified that it is composed only of G-PON standards, making it possible to choose any of the options previously mentioned. The NG-PON2 standard has an attractive feature concerning implementation costs and demand growth, designated as "pay as you grow" [16]. Even with the use of TWDM technology, it is not necessary to immediately use the four p-channels initially revised. The introduction of each of them can be done in a way that better

shapes the scenario in which the network finds itself. Therefore, it is possible to provide a single channel of 10/2.5 or 10/10 Gbps, in the *downstream and upstream* directions, respectively, and as the need arises, add more channels to the same network [17].

This operation is analogous to the XG-PON and XGS-PON technologies, which makes it a viable option in both the short and long term, as it provides the same bandwidth capacity as the successor technologies of G-PON, as well as offering a planned growth path with the introduction of more wavelengths in the same fiber. and by making better use of existing infrastructure. Therefore, the migration that seems to be more appropriate is the flexible one, aiming at users who have a higher band width demand profile for the provision of services in NG-PON2, using at the beginning only one wave length. Another aspect to consider is that those users who remain in the G-PON standard would benefit from an increase in their transmission rates since this standard uses the TDM (*Time Division Multiplexing*) multiplexing technique in the *downstream* direction. for data transmission, more time slots would become available, resulting in a better service for those who remained in the technology in operation. Thus, it is necessary to carry out a survey to determine the users who have a high bandwidth consumption, because they are natural candidates for migration in the short term, in addition to making projections for those who want growth in the medium and long term, taking into account potential availability of bandwidth that will be generated with the transposition of the first users to the NG-PON2 standard.

Thus, for the implementation of the migration, it will be necessary to exchange the UN equipment of the users that will be served by NG-PON2, adding to the CO the equipment compatible with the *line cards* that are standardized with the series of recommendations G.989 of the ITU-T. These *line cards* provide interfaces connecting to the fiber optic network itself or compatible optical transceivers. Compatible with the main equipment of the tip (OLT and UN), it is also necessary to modify the connection interfaces of the fibers that will serve users who use different standards, according to the diagram of the network structure shown in Figure 8. Thus, wavelength multiplexers should be introduced at the output of the OLT NG-PON2, in which each wavelength coming from one of the OLT ports must be configured so that there is no repetition between them within the same fiber [18].

Figure 8 – Block diagram of an NG-PON2 network

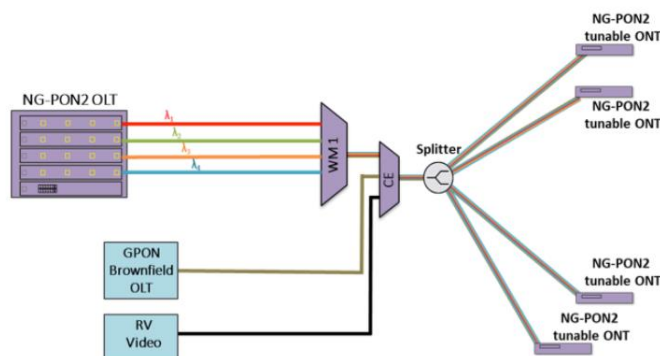

Source: Broadband Forum [18]

The output of this equipment is introduced into the coexistence element (CE_x), along with the output of the OLT G-PON in operation, and possibly an interface for OTDR may be made available, to improve network monitoring. An evaluation must be carried out to determine whether the introduction of such equipment will not result in an insufficient signal power level, as they introduce coupling losses in the connectors and in the equipment itself [7]. From this time, the power of the NG-PON2 network transmission shall be calculated; and of those who are in the G-PON network, it is necessary to reevaluate the links, because a set of equipment of a passive nature was added to the network in comparison to the previous structure.

For next-generation networks (NG-PON), service providers expect increased bandwidth and service support capabilities in their existing PONs. While NG-PON2 networks are considered the most promising approach, service providers need to deal with evolving patterns[19].

In the service environment, Verizon [20] is one of the main companies that use and make investments in this technology, establishing partnerships with Calix [21] companies to provide equipment such as OLTs and UN, and has already made investments in companies such as PICadvanced [22] for the development and production of optical transceivers. This company also has NG-PON2 networks operating in New York City for residential service, demonstrating the ability to implement this type of network.

5 CONCLUSION

The study described in this article was carried out to develop an analysis of the structure of the Giga Metrópole network that uses the G-PON passive optical fiber technology, to evaluate alternatives to increase its capacity and improve the quality of the services offered by PoP-RN, in a process of gradual migration GPON to NG-PON2.

The results suggest the possibility of proposed migration, leading to improvements in bandwidth availability, going from the 2.5 Gbps offered by G-PON to rates of up to 40 Gbps, with possible expansions of up to 80 Gbps in NG-PON2, demonstrating an increase of up to sixteen times in the current transmission rate, enhancing the provision of better performance and the offer of new services. NG-PON2's wavelength plane coexists with the wavelength planes of previous PON systems such as G-PON, XG-PON1, and radio frequency(RF) video overlay, enabling the reuse of existing infrastructures.

One of the most relevant aspects that emerged from the present study was the possibility of using the infrastructure of the installed optical distribution network, which according to [23] can cost 70% of the total value of the investments of a network in passive optical fiber, in addition to the possibility of gradual use of wavelengths in NG-PON2 technology, generating a smoother and more progressive migration curve, about the investments necessary to start the provision of services in this new standard and a better service of the needs of users, promoting an alternative for the availability of new services in the network, including good traffic support to meet the demand of applications that require a lot of bandwidth.

Studies have advanced in discussions on the aspects of quality, safety, feasibility, and practicality of the NG-PON2 system and point out the possibility of using this technology in FTTX networks, as a *backhaul* of the new generation of mobile telephony, contemplating 5G [11], because it presents favorable characteristics for its use to fulfill one of the main advances that this generation of mobile telephony demands, it being the eMBB (*Enhanced Mobile Broadband*) [24].

Finally, it is concluded that the programmed migration, gradual and focused on the results of each institution is the best option for the implementation of this new NG-PON2 fiber access network technology, and it is recommended to develop complementary studies to better detail the establishment of the transition phases and the investments for a new system in the network in PoP-RN , contemplating the technical and economic feasibility of the proposed solution, the need for changes in the infrastructure of the installed network and the analysis of the candidate users to be served by the migration to the new system, according to their needs of bandwidth and security utilization.

REFERENCES

- [1] RNP. **Rede Nacional de Ensino e Pesquisa**. Disponível em: <https://www.rnp.br>. Acesso em: 21, jul., 2022.
- [2] PoP-RN. **Ponto de Presença da Rede Nacional de Ensino e Pesquisa no Rio Grande do Norte**. Disponível em: <https://www.pop-rn.rnp.br>. Acesso em: 30, set., 2019.
- [3] IMD. **Instituto Metr pole Digital**. Disponível em: <https://www.Metropoledigital.ufrn.br>. Acesso em 21, jul., 2022.
- [4] HOOD, D.; TROJER, E. **Gigabit-Capable Passive Optical Network**. 1^a ed. John Wiley & Sons, 2012.
- [5] ITU-T, “**ITU-T Recommendation G.984.2 - 40-Gigabit-capable passive optical networks 2 (NG-PON2): Physical media dependent (PMD) layer specification**. 2014.
- [6] ANSARI N.; ZHANG, J. **Media access control and resource allocation: For next generation passive optical networks**. Springer Science & Business Media, 2013.
- [7] KEISER, Gerd. **Comunica es por fibra  ticas**. 4^a ed. AMGH, 2014.
- [8] PINHEIRO, J.M.S. **Redes  ticas de Acesso em Telecomunica es**. 1^a ed. Elsevier, 2017.
- [9] International Telecommunication Union. **Transmission systems and media, digital systems and networks**
- [10] ALMEIDA, F. R.; SILVA, G.S.; PINHEIRO, F. S. R. **Estudos e Solu es para Provimento de uma Infraestrutura de Rede FTTH em uma  rea Residencial Multicondominial**. Conciliun. Vol. 22, N  7. 2022
- [11] GOENOPAWIRO, J.M. **Next Generation Mobile Network Supported By NG-PON2. 2018**. Tese de Mestrado em Engenharia El trica e de Computa o – Universidade de Coimbra, Coimbra, 2018.
- [12] NESSET D., **NGPON2 technology and standards**. 2014 The European Conference on Optical Communication (ECOC), 2014, pp. 1- ECOC.2014.
- [13] International Telecommunication Union. **Transmission systems and media, digital systems and networks**. [Online]. Available: <http://www.itu.int/rec/T-REC-G/en>
- [14] Nakayama Y. Hisano D. **Wavelength and Bandwidth Allocation for Mobile Fronthaul in TWDM-PON**. IEEE Transactions on Communications, Vol. 67, N . 11. 2019
- [15] ITU-T G.989.3- **40-Gigabit-capable passive optical networks (NG-PON2): Transmission convergence layer specification**. 2015.
- [16] ITU-T G.989.1- **40-Gigabit-capable passive optical networks (NG-PON2): General requirements**. 2013.
- [17] VIANA D. F. R. **Coexist ncia de Redes de Acesso de Nova Gera o**. Tese de Mestrado em Engenharia El trica e Telecomunica es. Universidade de Aveiro. 2013

- [18] Broadband Forum (2019). **NG-PON2. The future of Passive Optical Networking is Here.** Disponível em: <https://www.broadband-forum.org/download/MU-437.pdf>. Acesso em 20, jul., 2022.
- [19] MOENCH, W.; CLAGUE, D. Challenges in Next-Gen PON Deployment. **Viavi Solutions**, 2021. Disponível em: <https://www.viavisolutions.com/en-us/literature/challenges-next-gen-pon-deployment-white-papers-books-en.pdf>. Acesso em: 20, jul. 2022.
- [20] GOOVAERTS, D. **Verizon VP: NG-PON2 will make future fiber upgrades easier.** **Fierce Telecom**, 2022. Disponível em: <https://www.fiercetelecom.com/broadband/verizon-exec-ng-pon2-will-make-future-fiber-upgrades-easier>. Acesso em: 20, jul., 2022.
- [21] Calix (2018). **NG-PON2 Calix Deployment Guidelines.** Disponível em: https://www.calix.com/content/dam/calix/marketingdocuments/public/Calix.Whitepaper_NG-PON2_Deployment.pdf. Acesso em 20, jul., 2022.
- [22] Verizon. **Verizon Ventures' PICadvanced investment to further the adoption of NG-PON2.** Disponível em: <https://www.verizon.com/ventures/blog/2020/8/verizon-ventures%E2%80%99-picadvanced-investment-to-further-the-adoption-of-ng-pon2/>. Acesso em 20, jul., 2022.
- [23] LEMMENS, J.L. **ODN Innovation: value lever for the telecom industry.** **IDATE**, 2022. Disponível em: <https://en.idate.org/odn-innovation-value-lever-for-the-telecom-industry/>. Acesso em: 20, jul., 2022.
- [24] SILVA J.L. A.; PIHEIRO, F. S. R.; SILVA, G. S.; SOUSA, V.A.J. **Contribuições ao estudo de planejamento para implantação de uma rede de acesso 5G em uma área urbana adensada em Natal.** *Brazilian Journal of Development*. Maio. 2022.