 <https://doi.org/10.56238/alookdevelopv1-012>

Jose Pedro Leal Soares

Master's Degree in Technology of Constructions and Structures Fluminense Federal University
E-mail: josepedrolealsoares@id.uff.br

Luiz Carlos Mendes

PhD in Civil Engineering Fluminense Federal University
E-mail: lcarlos@predialnet.com.br

ABSTRACT

The knowledge about the types of materials and profiles in structural projects has become increasingly important with the advance of technology in structural areas. The evolution of the cross-section geometry of a profile is of paramount importance to generate great efficiency in the structural area along with other benefits such as low production costs. In this research, the results of a study on the stability behavior of cold-formed steel bars with Z90 cross-section chosen through NBR 6355:2012 are presented and discussed. The applicability or not of V-shaped ribs in the web and/or in the flanges of the profiles is considered, which occur compression load at their ends and being studied for each example a simply supported

member. The research aims to analyze the structural behavior of the profiles, identifying the different behaviors for each type of cross-section studied with the deformation modes that occur and to reach a conclusion as to the use of ribs being an important factor for increasing the resistance of the bar. Analysis of structural stability was performed identifying geometries affected by instability phenomena with the help of the GBTUL program, which uses the Generalized Beam Theory generating the results of bifurcation loads and modal participation diagrams that are of great importance to verify the structural behavior of the studied profiles. With the results generated, the profile with the introduction of ribs both on the web and on the flanges had higher resistance, followed by the profile with ribs only on the web, in third place the profile with ribs only on the flanges and with the lowest resistance, the profile without ribs. Thus, it can be concluded that the introduction of ribs generated a greater resistance of the profile regarding the compression load applied at its extremities.

Keywords: Structural stability, Instability phenomena, Ribs, Generalized Beam Theory, Deformation modes.

1 INTRODUCTION

The technological advancement of engineering projects and materials studies has generated solutions within the engineering of great efficiency in the structural area along with low production costs, in addition to the predisposition of the use of structures of fast execution, lighter, and low thickness. This search for greater efficiency has given rise to several structural solutions, such as the use of metal structures because it is one of the most advantageous.

The high strength and considerable ductility of metals, especially steel, combined with several benefits of its use, make this solution more and more used and competitive in structural terms, giving rise to more slender elements. Within structural calculus, a very significant concept is that of slenderness,

where it is evaluated how much a compressed bar becomes or does not become vulnerable to the effect of flamber. This concept is of vital importance to verify the risk of collapse of the structure.

The high slenderness of structural elements ends up making them very susceptible to instability phenomena, which demonstrates the importance of the study of the stability and structural behavior of thin-walled sections, in particular those made of cold-formed steel. Steel structures, in general, have a variety of advantages when compared to other types of structures, such as the conventional reinforced concrete construction system.

According to Torres (2014), cold-formed steel profiles are characterized by presenting a differentiated relationship of their width and thickness, which has some different characteristics as to their structural behavior that is influenced by deformation phenomena, these few being relevant or even nonexistent in welded or hot-rolled profiles.

The non-use of structures with exaggeratedly thin walls can be applied when there is a high risk of fire, corrosion, and severe physical damage to the structure, but considering the economic factor, its strength, and the low weight of the material, the use of thin wall structures still advances significantly in civil construction.

2 STRUCTURAL STABILITY

Structural stability is a concept of great importance associated with the notion of equilibrium. A structure that has external loads being applied to itself displays an equilibrium configuration obtained by the displacement values. The behavior of the structure subject to this applied external load defines its structural stability. According to Santana (2014), with the end of the application of the external load, the structure can return to its initial form, which guarantees a stable balance, or not return to its initial form and present an unstable balance. The alteration of the state of tension of the structure induces the emergence of phenomena of structural instability. This concept, also called buckling, occurs in profiles subject to compression load that can be analyzed alone or together with a given structure.

The transition from stable and unstable equilibrium configurations is seen by evolution along an equilibrium trajectory. The increase in the relationship of the load to the displacement allows for determining the critical load responsible for the change from the initial configuration to one of unstable equilibrium.

3 PHENOMENA OF INSTABILITY

The analysis and sizing of cold-formed steel profiles require the need to consider the different instability phenomena that can occur in the bar as a whole. Bars made of cold-formed steel are generally very slender, subject to different modes of instabilities, and may sometimes lead to a state of collapse.

Global instability is characterized by the deformation of the longitudinal axis of a bar, where its cross-section undergoes displacements of the body of its plane, which may be of rotation and/or translation as shown in Figure 1. According to Dôres (2014), the following are the most common examples of global instability:

(i) Instability of compressed bars:

- a) Bending around one of the main inertia axes of the cross-section due to the compression load greater than the critical one (Figure 1(a)).
- b) Torsion, characteristic of bars with cruciform cross-section, when the buckling of all the plates occurs by flexion simultaneously and in the same direction (Figure 1(b)).
- c) Flexo-torsion is a case that occurs in bars of monosymmetric sections, in which the position of the centroid does not coincide with that of the center of torsion, subjected to a compression load acting on its center of gravity (Figure 1(c)).

Figure 1: Global instability of columns: (a) Flexion; (b) Torsion; (c) Flexion-torsion

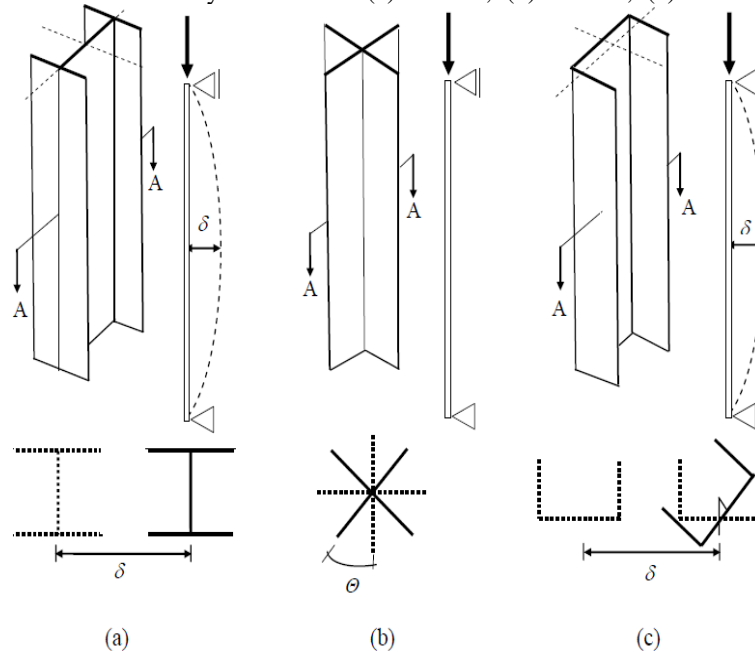

Source: Dôres (2014).

(ii) Lateral instability with torsion on bars subjected to flexion:

- a) They are characterized by the translation, in their orthogonal direction, to the plane of loading and rotation around their longitudinal axis, which passes through the center of torsion of the section, as exemplified in Figure 2.

Figure 2: Lateral torsion instability

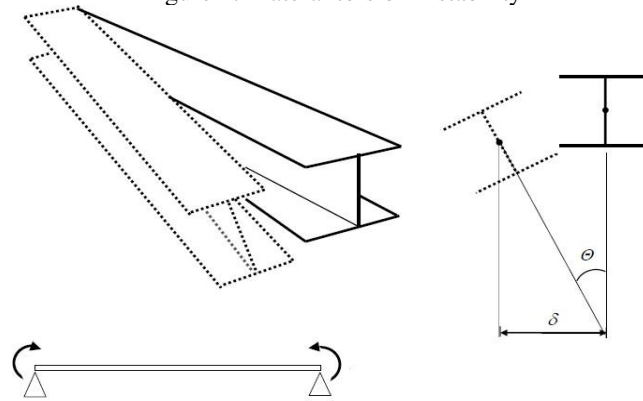

Source: Dôres (2014).

Local instability is characterized by the deformation of the walls of the section of a bar in its plane and remaining the longitudinal axis of the profile in the configuration undeformed. Local instability can be classified into two categories, which are associated with distortional modes (flexion of walls with significant displacements of one or more internal longitudinal edges) and local plate modes (flexion of the walls without displacement of the internal longitudinal edges).

Exemplifying:

- (i) Distortion modes are highlighted in profiles with stiffeners, such as those of the type U, Z, and Cartola, being more requested in those formed by steels of great mechanical strength. Its deformations are attributed to the occurrence of buckling by torsion of part of the section and due to the inevitability of reconciling the rotations in the edges that join the plates, it arises as a consequence of deformations by flexion in the adjacent plates existing displacements in the folds, changing the shape of the cross-section.
- (ii) Local plate modes present displacements by flexion of the soul because it is more slender, and this fact also occurs by the remaining plates due to compatibility. The longitudinal axis remains undisturbed, there is no displacement in the original position of the edges of the cross-section or any change in the angulation formed between adjacent plates.

The different deformation modes can be seen in Figure 3. The following explanations of the deformation modes presented, critical load and length of the bar subjected to compression can be briefly established:

- a) Plate location – They are predominant in short bars with very final plates.
- b) Distortion – Occurs on bars with intermediate slenderness.
- c) Global – They typically occur on long bars with great slenderness.

Figure 3: Deformation modes of a cross-section E_u

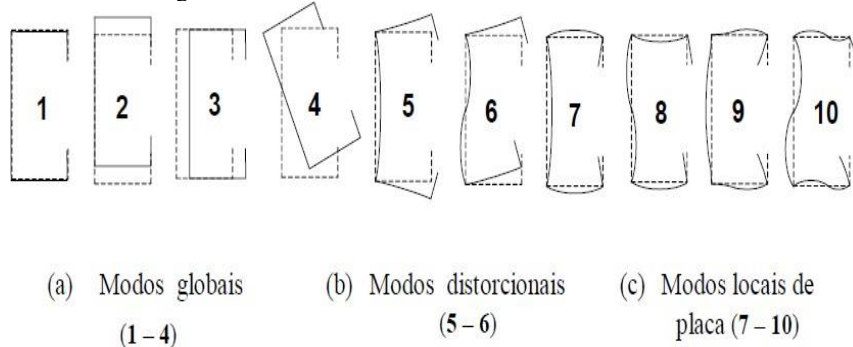

Source: Dôres (2014).

According to Alves (2008), the profiles of slender-walled rods are widely used as elements of beam structure, being very sensitive to the phenomena of instability. These profiles, conditioned to the phenomena of instability, present the local modes or the global modes of buckling. In local modes, the plane of the cross-section of the bar undergoes geometry deformations, with the longitudinal axis deformable. The global modes produce deformations in the geometry of the longitudinal axis, remaining invariant in the cross-section of the bar.

4 INTERACTION BETWEEN MODES OF DEFORMATION

The structural elements with sections of thin and open walls, more precisely, the cold-formed steel profiles have a greater vulnerability to the existence of interaction phenomena of deformation modes because use low thickness plates for the profiles.

Cold-formed steel profiles of open, slender, and monosymmetric sections are led to reduced stability by the integration of two or more deformation modes, such as local plate mode and global mode. In distortion mode, each component of the plate undergoes distortion with lateral displacement.

According to Barreta (2011), the identification of interactions of strain modes in a profile with thin walls occurs from the linear analysis of stability (i) determining curves that demonstrate the variation of the bifurcation load (P_b) with the length L of the bar and (ii) the identification of the L values for which the synchrony between the bifurcation loads for the two or more existing instability modes is noted.

Figure 4 shows three curves P_b vs. L for a simp supported profile when only a half-wavelength is admitted for the different strain modes.

Figure 4: Curves P_b vs. L for the different deformation modes

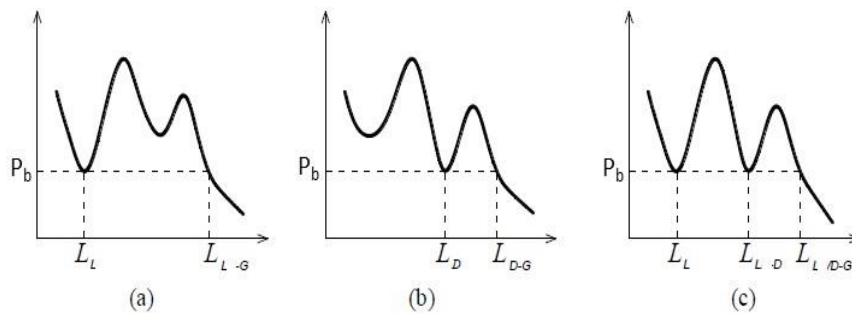

Source: Barreta (2011).

The observation of this figure allows us to identify the following interaction phenomena modal:

- (i) Interaction between local and global (L/G) modes. This interaction is associated with the length $L_{L/G}$ in Figure 4(a), which normally corresponds to a deformed configuration of the profile with a global half-wavelength and "many" local semi-wavelengths. It is observed that in the figure only the curves associated with instability with a single semi-wave are represented.
- (ii) Interaction between distortional and global modes (D/G). This interaction only occurs when the distortional minimum is less than the local and is associated with the length $L_{D/G}$ represented in Figure 4(b), which corresponds, in general, to a deformed configuration of the profile with a single global half-wavelength and "few" distortional wavelengths.
- (iii) Interaction between local and distortional modes (L/D). This interaction is associated with the $L_{L/D}$ lengths in Figure 4(c), which usually corresponds to a deformed configuration of the profile with a single distortional half-wavelength and "some" local half-wavelengths.
- (iv) Interaction between local, distortional, and global modes (L/D/G). This interaction is associated with the length $L_{L/D/G}$ of Figure 4(c) and involves a deformed configuration with an overall half-wavelength, "few" distortional semi-wavelengths, and "many" local semi-wavelengths.

5 GENERALIZED BEAM THEORY

The Generalized Beams Theory was developed in Germany in 1966 by the professor at the Technical University of Darmstadt, Richard Schardt. It is an efficient method for analyzing the geometrically nonlinear behavior of prismatic bars with open thin-walled sections, based on the introduction of the usual kinematic hypotheses of Kirchhoff (1883), the theory of distortion of

prismatic bars of Vlasov (1959), called the Generalized Coordinate Method and the classical theory of bars (Born, 1954 and Girkmann, 1959) according to Peres (2015).

This theory accounts for the global effects, which are relative to the deformation of the bar axis, and the local effects, which are associated with the deformations of the cross-sections of the bar in their plane, also approximates the deformed configuration of the cross-section of the bar through a linear combination of strain modes, presents objectively the solutions of problems of nonlinear problems involving sections of thin wall section opened because of their modal nature and offers other possibilities to the calculator about structural analysis where the same can not grant in other methods of numerical analysis.

The Generalized Theory of Vlasov has similarities with the classical theory of bars such as the equilibrium equations and boundary conditions, which drives the external structural behavior in quantities that depend on an axial coordinate and incorporates the theory of folded plates, and considered the local effects. This theory is defined in two stages, the first being the analysis of the bar in the identification of the deformation modes of the section and the determination of the modal mechanical properties. The second stage involves defining the loads, types of support and ending with the solution of the equilibrium equations.

To exemplify, Figure 5 demonstrates the singular discretization process that uses the approximation functions defined in the entirety of the midline of the cross-section, which can be rigid body movements or deformed configurations in its plane. It is possible to observe a defined structural behavior, in which the degrees of freedom (β) are modal values of the amplitude of the modes of deformation of the cross-section. Generalized beam theory makes numerical implementations clearer and more categorical with fewer degrees of freedom and a better interpretation of the results obtained.

Figure 5: Generalized Beams Theory through a U-Cross Section

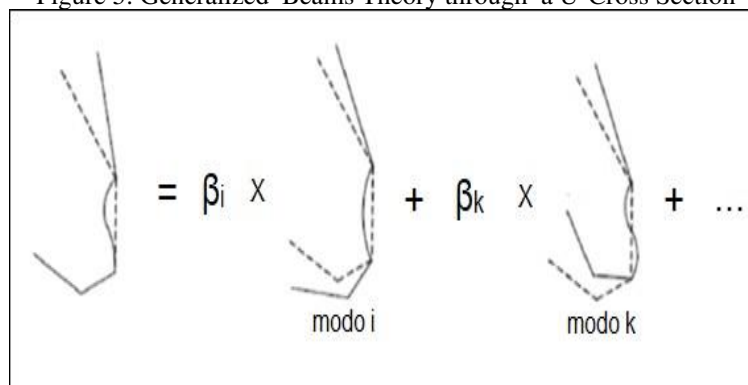

Source: The author (2021).

6 GBTUL PROGRAM

According to Bebiano (2018), GBTUL is a computer program developed by the Department of Civil Engineering of the Instituto Superior Técnico of the University of Lisbon – Portugal. For this article, we used the most up-to-date version of the program, version 2.06 of the program.

The program uses the formulations of the Generalized Theory of Beams, performing a stability analysis, which will be used in this article, and an elastic analysis by the vibration of sections of thin open walls. The program aims to determine the value of the critical load of a profile and identify the nature of the corresponding instability mode. Two types of solutions are considered, the first is the analytical for boundary conditions of the profile simply supported and with loads applied to the outer section of the bar and the numerical one that involves the discretization of the bar in finite elements and allows the application of different types of loads on the bar and contour conditions of the type embedded, set supported and simply supported.

The program provides as a result graphs and a list of length L that matches a load parameter P_b resulting in a curve that exposes the evolution of the relationship between these two factors. Along with this result, the program also provides a modal participation diagram and enables the visualization of the deformed profiles in 2D (cross-section) and 3D (the entire bar).

The GBTUL interface is formed by four screens with different characteristics, the first three deal with data entry, and the fourth of them provides the output of the results. Later the input data for the program will be described, but on the first screen, the characteristics of the material and the geometry of the section are defined. On the second screen, you select the type of mode and view the modes of deformation. On the third screen you select the type of solution and analysis, define the length of the bar, boundary conditions, types of loading, and the number of nodes. In the fourth and final screen, the curves of P_b vs. L and ω vs. L , the 2D and 3D deformation configurations, and the modal participation diagram are obtained. The curves P_b vs. L show the values of the bifurcation charge of the bar by its length. The user can define the number of strain modes he wants to take in the analysis to obtain the stresses for each type of instability that arise in the bar. In the case of a simply supported bar, the solution is analytic: the curves are obtained by trigonometric functions to describe the longitudinal variation of the displacements. In the case of the set bar, the solution involves discretizing the finite element length of the bar.

The modal participation diagrams report the variation of the contribution of the deformation modes of the respective instability modes existing in the bar. With these diagrams, it is possible to detect even more than one mode of instability, occurring a combination of local, distortional and global modes.

7 DEFINITION OF THE PROFILE AND RIBBINGS

For the determination of the cold-formed steel profile for the referenced article, the NBR 6355:2012 standard – Structural profiles of cold-formed steel – Standardization was used. This standard establishes the requirements of the structural profiles of cold formed steel with open cross-section, in addition to informing through frames the existing profiles with section U, Ue, Z90, Z45 and Cartola. For the Z90 cross-section of the article, the profile 100 x 50 x 17 x 1.20 was chosen, where all dimensions are in one thousand kilometers (Figure 6).

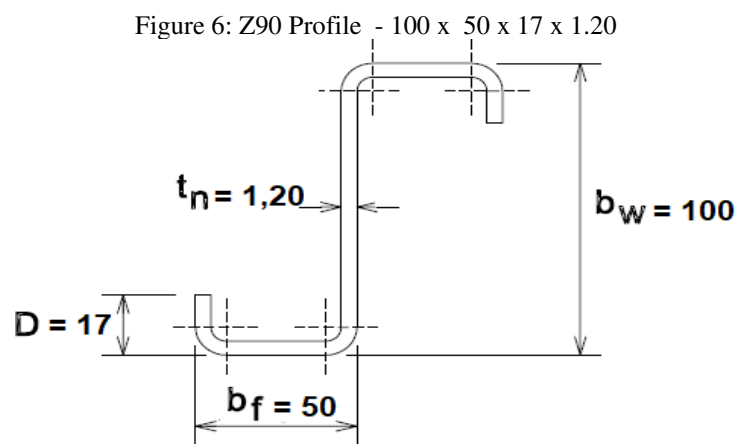

Source: The author (2021).

The rib studied, for the analyses made in the course of the article, has its shape in "V", having its dimensions of 20 mm of base and 10 mm of height and if applied for comparison purposes both in the table, soul and in both observing its cross-section. The use of this characteristic in the intermediate points of the walls of the cross-section aims to try to increase the resistance of the profile with the phenomena of instabilities mentioned above.

The application of ribs in the profile is of great importance for the cases of bars considered short and intermediate, since it is with these lengths that phenomena modes of local/distortional instabilities can occur. It should be taken into account that buckling by local instability is influenced by the slimmest element (usually the soul) and distortional instability involves the rotation of the table-rib set around the table-soul connection, where the load is critical being influenced by the dimensions of the table and rib.

It should be noted that the ribs reduce the local slenderness of the profile walls through the subdivision of smaller wall segments, increasing the value of critical tension as if it were a kind of set of elastic supports.

8 DATA ENTRY NO GBTUL

To be able to acquire the results for later analysis, the GBTUL program will be used as previously described.

The first procedure is the introduction of the data and geometry of the profile, being used for the referred article steel with a modulus of elasticity (E) with the value of 200000 MPa; Poisson coefficient (ν) with the value of 0.3; transverse modulus of elasticity (G) with the value of 77000 MPa and specific mass (ρ) with the value of 7850 kg/m³. For the geometry of the profile, you must select the type of section to work with, where the program has several different formats and with the selected section, put its dimensions (mm). The type of profile chosen for this article has been cited previously.

The second procedure is (i) the choice of the deformation mode to be displayed in the section; (ii) the definition of the modes used for analysis (usually used the conventional modes) and (iii) the verification of the properties of the cross-section.

The third procedure is (i) the selection of the type of solution (analytical or numerical), and in this research, the analytical one is used; (ii) the loads applied to the structure, being in this research axial compression loads of 1 kN in the extreme zones of the bar; (iii) the types of support in the structure, being in this research a bi-supported structure; (iv) the dimension of the bar, being in this research a bar from 10 mm to 10 m; (v) half-wave lengths; (vi) number of nodes in the bar; (vii) 2D and 3D view of the bar with the applied loads;

(viii) the number of instability modes to be calculated and (ix) the selection of the type of analysis (buckling or vibration), being in this research used buckling.

9 GBTUL RESULTS

With the data entry phase completed, the GBTUL program in its last stage provides the results for the previously mentioned studied profiles. For this article, the results of the curve P_b vs. L will be considered and the modal participation diagram on of the existing numbering within the diagrams that will follow was defined by the legend of the GBTUL program itself.

The results provided in the GBTUL of the Z90 profile (100 x 50 x 17 x 1.20) will be displayed. In the first case it will be the profile without the application of ribs (Figure 7), then with ribbing applied to the soul (Figure 8), then with ribs applied to the tables (Figura 9) and at the end with ribs applied both in the soul as well as in the tables (Figure 10).

Figure 7: Z90 ribbed profile results

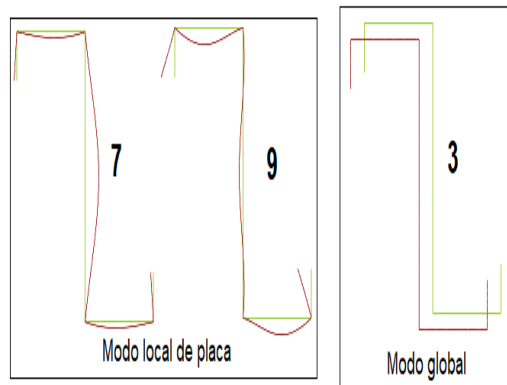
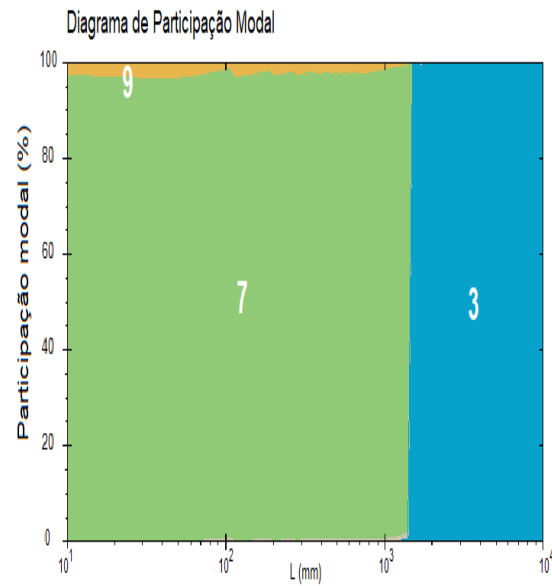
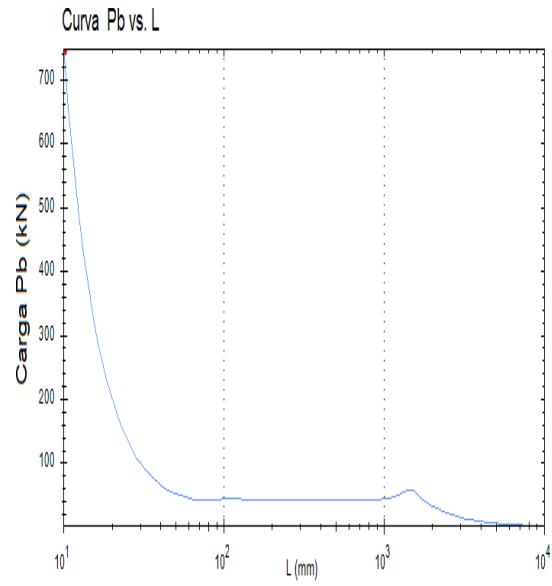

Source: The author (2021).

Figure 8: Z90 profile results with ribbed in the soul
Curva Pb vs. L



Diagrama de Participação Modal



Source: The author (2021).

Figure 9: Z90 profile results with ribs on tables
Curva Pb vs. L

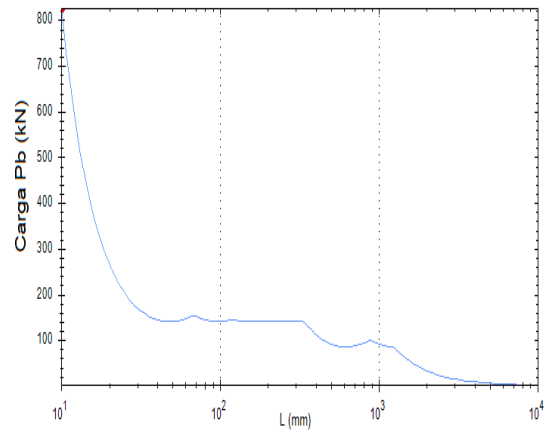
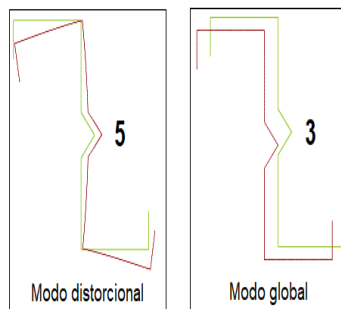
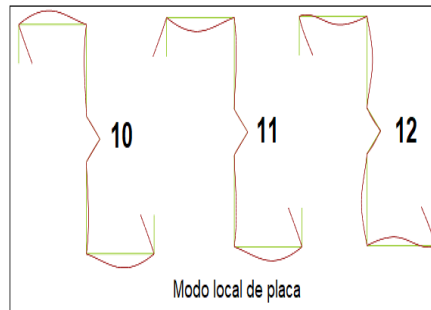
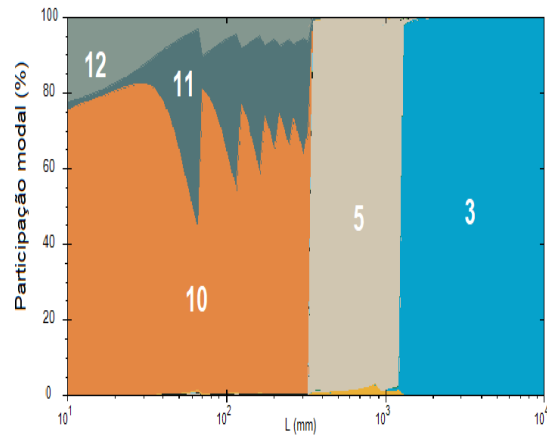

Diagrama de Participação Modal



Source: The author (2021).

Figure 10: Z90 profile results with ribs in the soul and tables
Curva Pb vs. L

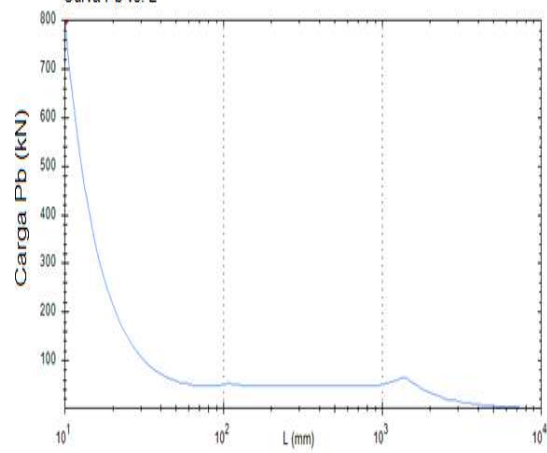
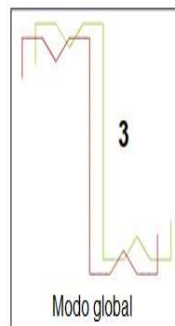
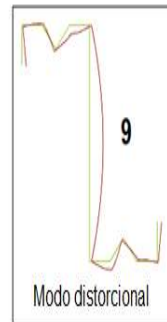
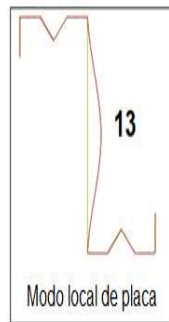
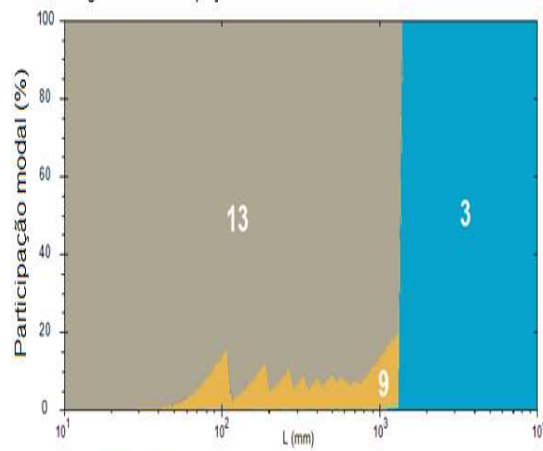
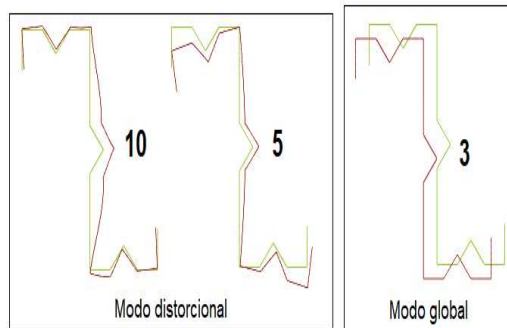
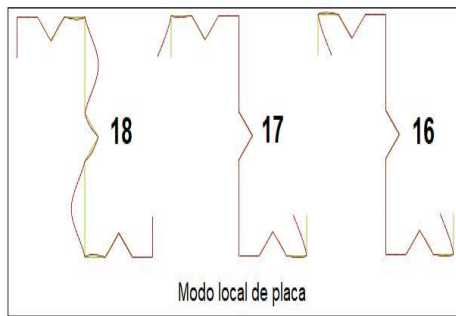
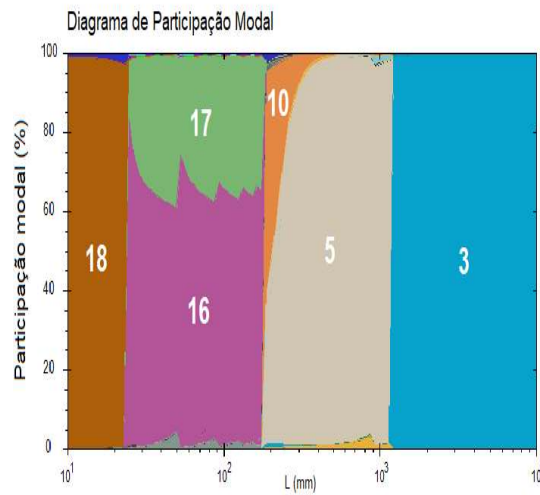
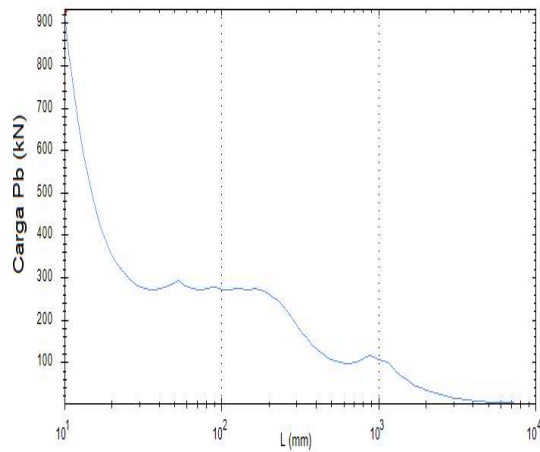

Source: The author (2021).

10 ANALYSIS OF RESULTS

With the results generated, they will be analyzed to obtain a better understanding of the structural behavior of the profiles submitted in this article through the modal participation diagram, the bifurcation loads by the length of the bar, and verify the different performances that occur.

By the division made by the GBTUL program of the graphs and diagrams provided and to facilitate the understanding, three nomenclatures will be defined about the length of the bar, namely:

- a) Short bar – From 10 mm to 10 cm.
- b) Intermediate bar – From 10 cm to 1 m.
- c) Long bar – From 1 m to 10 m.

1. In the analysis of the modal participation diagrams, the modes of deformation with percentages and minute variations, less than or equal to 1%, will not be considered.

10.1 MODAL PARTICIPATION DIAGRAM

For the results of the Z90 profile presented, first, the different structural behaviors of the barra will be analyzed through the existing deformation modes with the aid of modal participation diagrams observing the percentages Provided.

In Figure 7, where the Z90 profile has no ribs, local plate modes are observed (7 ranging from 97% to 100% and 9 ranging from 0% to 3%), which extend over much of the bar, reaching the beginning of the definition of "long bar". Then the strain modes change to the global mode (3 ranging from 97% up to 100%) which extends to the end of the bar.

In Figure 8, where the Z90 profile has to rib in the soul, local plate modes are observed (10 ranging from 46% to 70%, 11 ranging from 2% to 42%, and 12 ranging from 2% to 20%), which extend up to half of the definition of "intermediate bar". Then the strain mode changes to the distortion mode (5 ranging from 97% to 100%), which extends to the beginning of the definition of "long bar" where the strain mode changes to the global mode (3 ranging from 97% to 100%) which is enclosed to the end of the bar.

In Figure 9, where the Z90 profile has ribs on the tables, an interaction of deformation modes is observed, being of local plate mode (13 ranging from 79% up to 100%) and in a distortional mode (9 ranging from 0% to 20%) that extends to the beginning of the definition of "long bar". Then the interaction ends and there is the global mode (3 ranging from 97% to 100%) that extends to the end of the bar.

In Figure 10, where the Z90 profile has ribs both in ALMA and in the tables, local plate modes are observed (16 ranging from 60% to 76%, 17 ranging from 18% to 38%, and 18 ranging from 97% to 100%) that extend until almost reaching half of the Definition of "middle bar". Then the strain mode

changes to the distortional modes (5 ranging from 35% to 98% and 10 ranging from 0% to 64%), which extend to the beginning of the definition of "long bar" where the strain mode changes to the global mode (3 ranging from 97% to 100%) which extends to the end of the bar.

With the results reported, it is very clear that when it comes to the definition of "long bar", the structural behavior through the deformation modes remains almost the same in the four types of Z90 profiles of this research, Global mode (3) occurs in all profiles.

In the definitions of "short bar" and "middle bar", there are several behaviors of the structure. Observing the non-applicability of ribbing in the soul (Figure 7 and Figure 9), it is possible to observe a large percentage in a considerable length of the bar in the local mode of the plate that in this case presents displacements by flexion of the soul and for being more slender, also occurring in less displacement, by the remaining plates due to compatibility

The existence of ribbing in the soul (Figure 8 and Figure 10) in a large part of the definition of "intermediate bar" together with a small part of the definition of "long bar", it is possible to observe similar structural behavior in both profiles, having in these two cases the distortional mode (5). The only difference found is in the case of Figure 10, the also existence of the distortional mode (10), in addition to the greater length of the bar for these strain modes. In the definition of "short bar", a large difference in the structural behavior of the bar is noted.

10.2 FORK LOAD

In this step, the curves P_b vs. L will be analyzed to describe the variation of the bifurcation load by the three definitions of bars presented.

In Figure 7, where the Z90 profile has no ribs, in the definition of "short bar" is seen a large variation of the bifurcation load where it starts at 747 kN and ends around 43 kN. Next, in the definition of "middle bar", the variation of the bifurcation charge is almost zero and in the definition of "long bar" there is a slight slope at the beginning, reaching 57 kN, and after a slope to the end of the bar.

In Figure 8, where the Z90 profile has ribbed in the soul, in the definition of "short bar" is seen a large variation of bifurcation charge where it starts at 826 kN and ends at 140 kN. Then, in the definition of "intermediate bar", the variation of the charge of bifurcation is almost zero up to half of the same definition and after a slope occurs, reaching the end of it with a value of 90 kN in the definition of "long bar", where in this there is a slope to the end of the bar.

In Figure 9, where the Z90 profile has ribs on the tables, in the definition of "short bar" seen a large variety of the fork load where it starts at 800 kN and ends at 50 kN. Next, in the definition of

"intermediate bar", the variation of the bifurcation load is almost nil and in the definition of "long bar," there is a slight slope at the beginning, reaching 64 kN, and after a slope to the end of the bar.

In Figure 10, where the Z90 profile has ribs in both the soul and the tables, in the definition of "short bar" is seen a considerable variation of the bifurcation load where it starts at 933 kN and ends at 270 kN. Then, in the definition of "primary bar", a slope occurs over almost the entire length reaching the fork load of 105 kN. In the definition of a "long bar", a slope to the end of the bar occurs.

With the reported results, it is possible to identify that the ribbed profile applied both to the soul and the tables (Figure 10) obtained the highest values for the bifurcation loads in the three definitions of bar length, being in second the profile with ribbing applied in the soul (Figure 8), in third the profile with ribs applied in the tables (Figure 9) and last the profile without applied ribs (Figure 7).

A detail found in the definition of "long bar" was for the ribbed profile on the tables (Figure 9) and the profile without applied ribs (Figure 7). In the vicinity of the change of the deformation modes, a small slope occurs in the curve P_b vs. L , reaching the peak of this slope at the time of the change to the global mode (3) and after a slope to the end of the bar.

11 FINAL CONSIDERATIONS

Structural instability is one of the most significant causes of structural failures in thin-walled rod profiles. In the development of this article, we sought to show clearly and objectively the information and characteristics of steel profiles cold-formed, deformation modes and the use of tools such as computer programs to study the structural behaviors of the profiles, allowing a more in-depth analysis of the results. In this way, facilitates the understanding of these profiles as to their current geometry and making modifications aiming at a better performance as to their resistance.

It was found that the ribbed profile both in the soul and in the tables a greater resistance by the application of the compression load as the structural instability. This finding was possible thanks to the results obtained by the curves P_b vs. L where the values in kN of the bifurcation loads at each node of the bar were extracted.

The ribbed profile in the soul was the one that obtained the second-best resistance when applied compression loads on the bar. This finding can be explained because the existence of ribbing in the soul decreases the displacements by flexion in this region. After all, it is more slender.

The ribbed profile on the tables obtained the third-best resistance when applied compression loads on the bar and with the lowest resistances, the ribless profile was applied.

The results presented in this article were very satisfactory because it was possible to verify the structural behavior of the chosen profiles with the use or not of ribs in their cross-section and to define the geometries that present greater resistance regarding loads of compression.

Thus, it is concluded that this article lends original academic value, contributing to the analysis of cold-formed steel profiles, and enabling other branches of research with the incorporation of requirements of international standards.

REFERENCES

Associação brasileira de normas técnicas. Perfis estruturais de aço formados a frio. Nbr 6355, rio de janeiro, 2012.

De carvalho nogueira torres, rafaela. Análise de perfis formados a frio para utilização de enrijecedores. Dissertação de mestrado. Programa de pós-graduação em engenharia civil, universidade federal fluminense. Niterói, 2014.

D. Camotim, r. Golçalves. Generalised beam theory-based finite elements for elastoplastic thin-walled metal members. *Thin-walled structures*, p.1237-1245, 2011.

D. Camotim, r. Golçalves. Geometrically non-linear generalised beam theory for elastoplastic thin-walled metal members. *Thin-walled structures*, p.121-129, 2012.

Eduardo anicetode serra barreta, carlos. Interação entre Instabilidade local-de-placa e distorcional em colunas de aço enformadas a frio de secção em z. Dissertação de mestrado. Programa de pós-graduação em engenharia civil, instituto superior técnico, universidade de lisboa. Lisboa, 2011.

Golçalves rodrigues das dôres, andréa. Análise de elementos estruturais com secção transversal de parede fina aberta ramificada utilizando a teoria generalizada de vigas (generalized beam theory – gbt). Tese de doutorado. Programa de pós- graduação em engenharia civil, universidade federal de ouro preto. Ouro preto, 2014.

Manuel caixinha pinto santana, henrique. Estabilidade de colunas com secção em c reforçada. Dissertação de mestrado. Programa de pós-graduação em engenharia civil, instituto superior técnico, universidade de lisboa. Lisboa, 2014.

Rafael da silva peres, nuno. Formulação linear da teoria generalizada de vigas para barras de eixo curvo. Dissertação de mestrado. Programa de pós-graduação em engenharia civil, universidade nova de lisboa. Lisboa, 2015.

R. Bebiano, d. Camotim, r. Golçalves. Gbtul 2.0 – a second-generation code for the gbt-based buckling and vibration analysis of thin-walled members. *Thin-walled structures*, elsevier, v.124, p.235-253, doi: 10.1016/j.tws.2017.12.002, 2018.

Ribeiro alves, vancler. Análise de perfis enrijecidos em hastes de paredes delgadas de aços formados a frio. Tese de doutorado. Programa de pós-graduação em engenharia civil, universidade federal fluminense. Niterói, 2008.