 <https://doi.org/10.56238/alookdevelopv1-017>

Elvanger Santos Cardoso

Highest degree of training: Master in Industrial Assembly

Academic institution: Universidade Federal Fluminense.

E-mail: elvangers@yahoo.com.br

Antônio César G. Motta Filho

Highest degree of training: Master's student of the Professional Master's Degree in Industrial Assembly.

Academic institution: Universidade Federal Fluminense.

E-mail: antonio.cesar.g.m.filho@gmail.com

Paulo Roberto Duailibe Monteiro

Highest degree of training: Doctor in Civil Engineering.

Academic institution: Universidade Federal Fluminense.

ORCID: <https://orcid.org/0000-0002-7376-9115>

Larisa Alves Gomes

Highest degree of training: Student of the Undergraduate Course in Electrical Engineering.

Academic institution: Universidade Federal Fluminense.

E-mail: larisag@id.uff.br

ABSTRACT

This work aims to make a comparison between disconnecting circuit breakers (DCB) and conventional circuit breakers, with the purpose of evaluating the feasibility of implantation in several installations in Brazil that follow procedures and regulations of the agents of the Brazilian electric sector. The development of DCB technology has allowed an increase in the reliability and availability of the substations, which has contributed to the reduction of failures and, consequently, of the costs related to the maintenance of the substations that incorporate these types of circuit breakers in their projects [1]. It is worth mentioning that, due to the innovative technology of combining two functions (circuit breaker and disconnector) in the same protection device, DCB are not only reducing the amount of raw materials and the emission of gases that favor global heating, but also a relevant reduction of the space occupied by substations that adopt these types of devices in their projects, about 75%, thus resulting in substations more ecologically and economically sustainable substations [1, 2].

Keywords: Substation Design, New Substations, Compact AIS Substation, High-voltage Circuit Breakers, Disconnecting Circuit Breaker.

1 INTRODUCTION

TAKING into account the technological development in the early 2000s, which culminated in the possibility of integrating the peculiar functions, both of the circuit breakers, which are equipment that interrupt the defect currents at a certain point of the electrical circuit and the disconnectors, intended for the isolation of the electrical circuit or maneuver, in a single equipment, of According to [1] it can be said that the circuit breakers, based on SF₆ (sulfur hexafluoride), contributed to increase the maintenance interval by 15 years or more.

Many substations still use conventional circuit breakers with isolation switches due to the lower installation cost than DCBs. However, this article aims to demystify this subject.

On the other hand, for the open disconnectors, the evolution was limited to the reduction of costs related to the optimization of the materials used, which did not result in major improvements regarding the failures of maintenance, availability, and/or reliability of such devices [2]. The disconnecting circuit breakers also allow the elaboration of smarter and safer substations, since their

implementation, in the design phase, allows the removal of 2 (two) conventional disconnecter switches, ensuring the reduction, from 30 to 75%, of the area occupied by the substation [1, 2].

This work will be addressed the main configurations in the basic network of this circuit breaker, making the distinction of whether it is applicable or not.

2 EVOLUTION OF SUBSTATION PROJECTS

Previously, when designing substations, the premise was to include disconnectors upstream and downstream of the circuit breaker to allow its maintenance [3]. Thus, to reduce the failure rate of disconnectors and enable the safe maintenance of substations and transmission lines, there is a need for more appropriate sectioning, which could be achieved due to the development of disconnecting circuit breakers, which have the peculiarity of combining, in a single device, the functions of this two equipment [2, 3].

The DCB contact system is the same as that of the conventional circuit breaker (CB), there is no need for extra calls, and there is an additional feature (sectioning) that is guaranteed within the interrupting chamber, that is, when the circuit breaker contacts are open, in this position, it will meet all the requirements of a disconnecting switch (DS) [5].

As the sectioning function is performed inside the interrupt chamber, there is no visibility of the opening distance [1, 2, 4].

The main advantage of the disconnecting circuit breaker, about the conventional disconnecting switch, is that its electrical contacts are protected in an environment controlled by SF6 gas, which means that they do not suffer the effects of environmental conditions, as well as pollutants existing in the atmosphere, increasing the reliability, availability, and periodicity of maintenance [1, 2].

According to [1], another important feature of the disconnecting circuit breaker is the offer of safe working conditions during maintenance activities, since, when used to isolate electrical circuits, there is a need to lock (lock) the BC when it is in the open position, which can be accomplished through operating mechanisms that make it possible to perform the electrical and mechanical interlocks of the BC, as well as a mechanical locking of the main connection system of the pole of such a device (through the disconnection of the bar), ensuring greater safety for the personnel involved in the operation or maintenance of the substation (SE).

Fig.1 illustrates the development of BC and its corresponding reduction in failure and maintenance rates by type of BC.

Fig. 1. Failure and maintenance rates

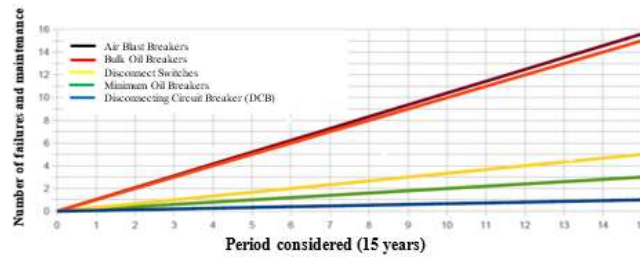

Source: Adapted from [3, 4]

3 STANDARDS APPLIED TO CIRCUIT BREAKERS AND DISCONNECTORS

A family of Standards was issued by the IEC (International Electrotechnical Commission) [5, 6, 7, 8, 9], to deal with the maneuvering devices and control mechanisms applied at high voltage or above, we can highlight, for example, part 108 of IEC standard No. 62271-108 that deals specifically with DCBs of alternating current and voltage equal to or above 72.5 kV [5]. In the table below, a list containing the main IEC standards applied to high-voltage devices follows.

Table I – Examples of IEC standards applied to high-voltage devices

IEC– 62271 (High-voltage switchgear and controlgear)	
Part:	Description
1	Common specifications for alternating current switchgear and control gear
100	Alternating-current circuit-breakers
102	Alternating current disconnectors and earthing switches
108	High-voltage alternating current disconnecting circuit breakers for rated voltages of 72,5 kV and above

Source: Adapted from [5, 6, 7, 8, 9]

4 SAFETY ASPECTS IN THE USE OF DCB

4.1 SUBSTATIONS WITH NO VISIBLE GAPS

For a long time, the visible open position of DS has been used as an indication of safety when working in Air Insulated Substations (AIS) [1, 2].

However, only the spacing itself does not guarantee sufficient safety to start any work in high voltage equipment and for this, it is necessary to do the local grounding [1, 2].

When a DCB is locked in an open position, it has the same function and dielectric resistance as a traditional disconnector [2].

To further increase security, it is always recommended to perform all operations remotely. SE with DCB uses motorized grounding switches that can be operated remotely as a safety measure in conventional solutions [1, 2, 3, 4].

4.2 SAFETY DISTANCES

Safety distances are defined by IEC 61936-1, but depending on local conditions, their values can be increased. Special attention should be paid to the minimum distance between the nearest "living" parts, also called the section clearance, which should be established between the energized parts and the switchboard location where the service will be performed by the personnel involved in the maintenance or operation of the SE [9].

4.3 POSITIONING OF GROUNDING SWITCHES IN BASIC ARRANGEMENTS

Depending on the configuration (single bus, double circuit breaker, or circuit breaker and medium) and the voltage level of the SE, the position of the grounding switches differs. According to Figures 2, 3, and 4.

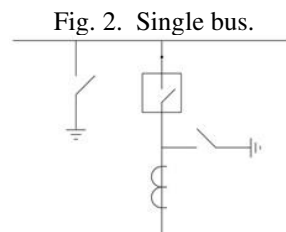

Source: adapted from [1]

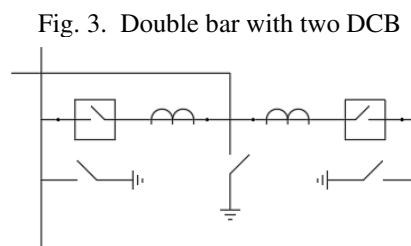

Source: adapted from [1]

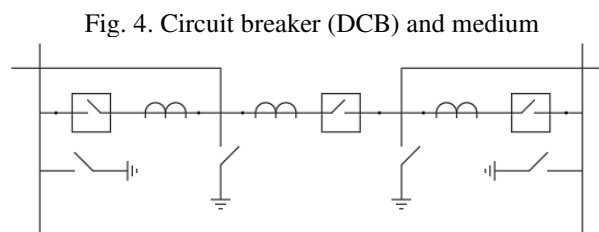

Source: adapted from [1]

The following is the symbology used in this document:

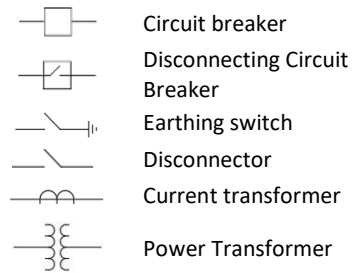

4.4 SUBSTATION INTERLOCK

The maneuvering procedure to perform the interlocking of an SE equipped with DCB is the same as a conventional SE, that is, after the mechanical blocking of the said circuit breaker, the output signal, indicating "open position", is sent to the interlocking system and, as soon as all the lines are disconnected and their respective voltages are equal to zero, The interlocking system will produce a release signal, thus allowing the closing of the grounding switch [1, 2].

4.5 DISCONNECT LINK

For the shutdown of the circuit breakers during the intervention process, it is necessary to disconnect them from a bus. Thus, said link is a point of the SE prepared for the fast opening between the primary connection and the circuit breaker and /or between the circuit breaker and the bus (Fig. 5) [1].

Fig. 5 – Disconnect link

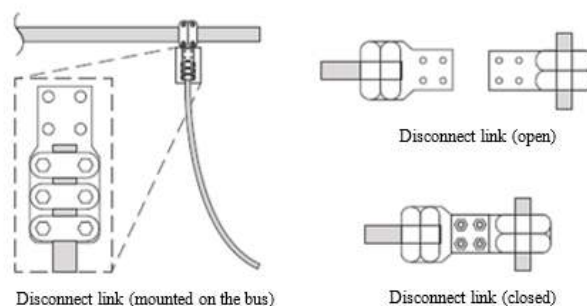

Source: [1]

When a DCB is isolated in this way, the other parts of the SE can be re-energized during work on the DCB itself. This increases the overall availability of the SE.

The disconnect link consists of standard clamps and a wire or tube. The link connection points are arranged so that when the link is removed, there is sufficient safety distance between the isolated equipment and the bus or line. This distance must meet the specific requirements concerning section clearance. Figure 6 illustrates where section clearance should be applied in different arrangements of substations.

Fig. 6 – Points with an indication of the application of the clearance

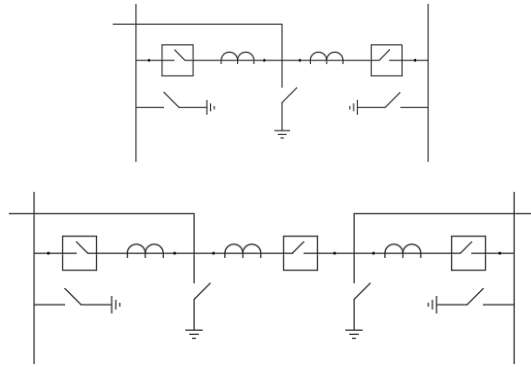

Source: adapted from [1, 2, 10, 11]

5 AVAILABILITY AND RELIABILITY

Currently, one of the biggest concerns of electricity transmission and distribution agents focuses on ensuring the uninterrupted supply of energy and, in this way, maximizing the continuity of service to the final consumer.

One of the ways to mitigate the interruption of electrical power is to design equipment that ensures high reliability with the least possible number of interventions during its useful life cycle, that is, SE that presents high reliability is designed with devices that have a low probability of failures [2, 3].

5.1 AVAILABILITY WITH DCB

By definition, the availability of an output element of an SE is the fraction of the time that electrical power is available at this point.

The main reason for the unavailability of an SE is maintenance, which should be expressed in hours per year.

Previously, CBs were mechanically and electrically complex and thus required many hours devoted to maintenance. Therefore, the main focus was on how to isolate the CB for maintenance and keep the other parts of the SE in service [1, 2].

Today, because modern circuit breakers (DCB) require less maintenance than conventional DS, the availability of SE is increased considerably.

5.2 RELIABILITY WITH DCB

Reliability can be expressed as the probability of a fault-free power supply at a given point during a specific period.

In this case, it can be stated that reliability takes into account only the frequency of failure and not the maintenance in the SE. So, its criticality is greater because it is an event that cannot be planned.

As the main feature of DCBs is the elimination of conventional SD, simplification of SE design is achieved, resulting in a low probability of failures, improvement of the arrangement, and greater reliability of the SE [2, 3].

5.3 COMPARATIVE ANALYSIS OF AVAILABILITY AND RELIABILITY IN A CONVENTIONAL 145KV SE (WITH CIRCUIT BREAKER AND DISCONNECTORS VERSUS DISCONNECTOR BREAKER)

For comparison purposes, it is considered a conventional dual-bus SE (Fig. 7) and a sectional bus arrangement equipped with a DCB, as per Fig. 8, where the conventional CB and DCB are connected to the bars.

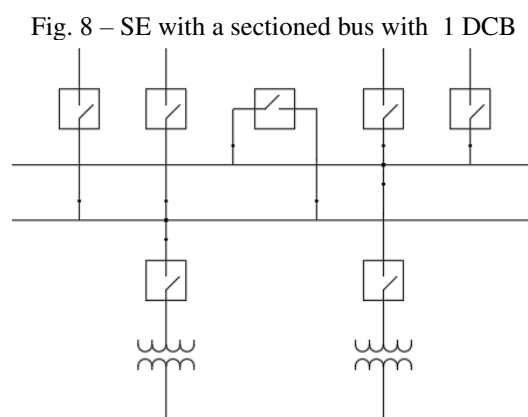
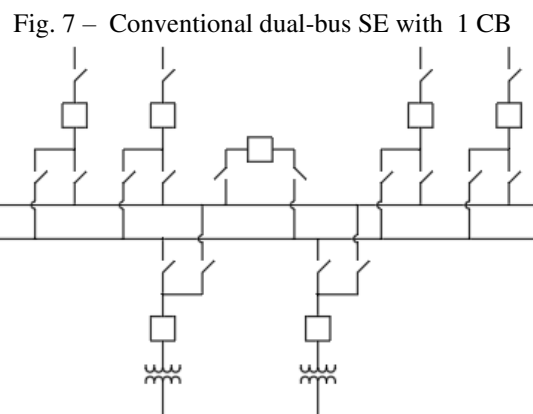

Source: adapted from [1, 2, 10]

The assumed maintenance intervals are five years for open-pit DS and fifteen years for DCB.

The introduction into the design of DCBs reduces the average unavailability due to the maintenance of a single compartment in the SE from 3.07 to 1.2 hours per year [2]. This comparison shows that the reliability of a single compartment in the substation will increase, thus decreasing the duration of failure from 0.17 to 0.15 hours per year (Fig. 9).

Fig. 9 – Interruption due to maintenance and failure

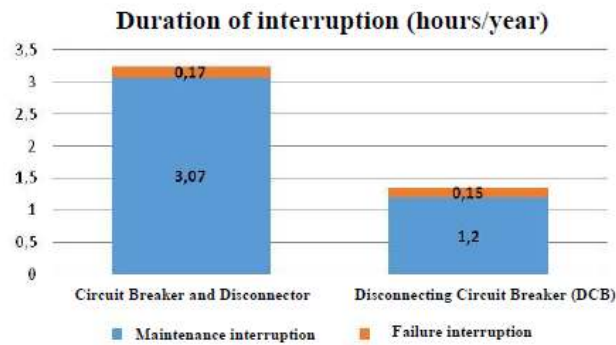

Source: adapted from [1, 2]

6 COMPARISON OF THE DIMENSIONS OF THE SE CONVENTIONAL WITH A SE WITH DCB

The development of the DCB integrated the functions of the CB and DS into a single unit, which culminated in the reduction of the space required for the design of a given SE.

Conventional SEs typically require more space between phases when compared to those using DCBs. In the case of a 145 kV SE, the required space reduction can reach 40%. (Fig. 10 and Fig. 11).

An interesting observation to make in the example of the substation design above is that with the replacement of the traditional configuration by DCB circuit breakers there was the elimination of 18 disconnectors. This reduction contributes to the reduction of space in the SE.

Fig. 10 – SE of the conventional double bus with 1 CB and 3 DS (54 x 77 = 4,158 m²)

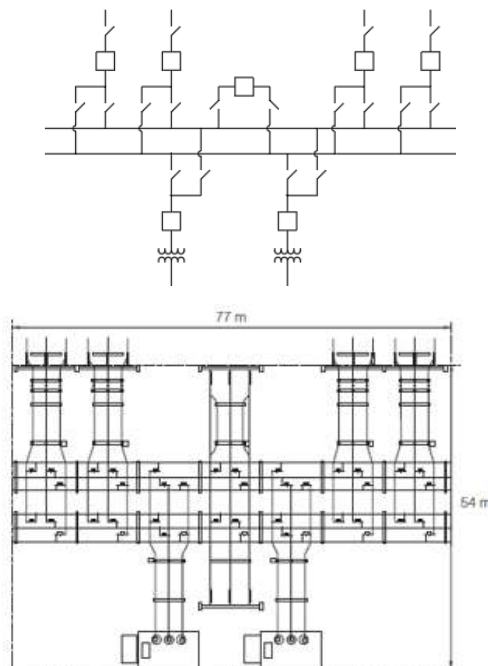

Source: adapted from [1, 2, 10]

Fig. 11 – SE of sectional bus and DCB (50 x 49 = 2,450 m²)

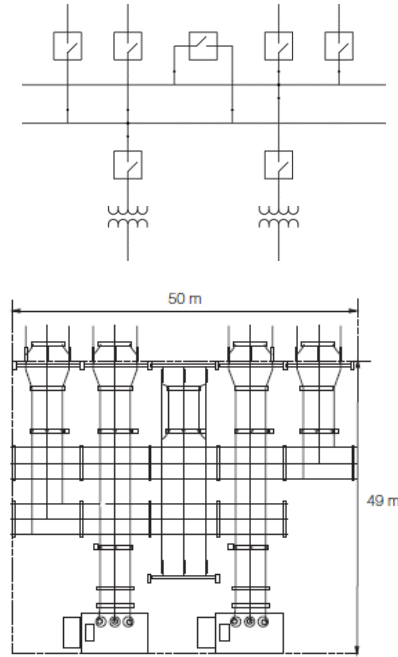

Source: adapted from [1, 2, 10]

7 ENVIRONMENTAL AND CONSTRUCTION AND ASSEMBLY IMPACTS

The use of DCB, in addition to reducing the area required for the SE project, also simplifies the secondary circuit referring to interlocking, that is, the said circuit can be dispensed with. In addition, energy losses related to conventional DS are mitigated [8].

As the number of primary equipment is reduced compared to conventional solutions, the use of raw materials is also significantly reduced.

The number of foundations required for an SE with DCB is much smaller than for a conventional one because the amount of equipment decreases. Typically, an SE with CBD needs only half or less the number of foundations compared to a conventional one [1].

Another important point is regarding the insulation and extinction of the electric arc of the DCBs that is made with SF₆ gas, and, as this type of gas contributes to the greenhouse effect, it should be handled with caution. The other innovative technology, according to [1] is the extinction of the arc using CO₂ which can completely replace the SF₆ in circuit breakers up to 84 kV. However, new technologies should always be well evaluated and tested, before deciding for their use in an SE project.

8 COSTS IN THE VARIOUS PHASES OF THE PROJECT AND OPERATION AND MAINTENANCE.

High-voltage equipment in a substation has a certain initial cost followed by several additional costs that accumulate over the life of the equipment. These calculations can be used as a powerful tool when comparing different SE solutions from the planning stage [1].

8.1 INITIAL COST

When the life cycle cost analysis is focused directly on the high-voltage equipment, the initial cost consists of the cost of purchasing that equipment and the costs associated with the foundations required to assemble the equipment. In this case, installation and commissioning costs should also be included [1].

From a broader perspective, it should be included the other elements in the costs, such as design, planning, project management, buses, and connections. These costs should generally be lower for DCB SE solutions than for conventional solutions, due to space and equipment reduction, as well as the use of partially pre-designed solutions.

8.2 MAINTENANCE COST

The cost of maintenance over the life of the equipment will depend on the maintenance intervals and their duration. Visual inspections and scheduled maintenance should be included in this item, as well as hourly rates for service staff [1].

8.3 REPAIR COSTS

Repair costs depend on equipment failure rates and repair times and spare parts cost. Repair costs depend on hourly rates of service staff, crane rental costs, etc.

8.4 COSTS OF ELECTRICAL LOSSES

The electric current of the SE results in electrical losses both in the high-voltage equipment and in the connections between them, so the electrical losses depend on the magnitude of this current. When different SE configurations are compared, the interconnects should be chosen similarly [1].

The costs of maintenance, repairs, and electrical losses gradually increase over the life of the equipment. These costs should therefore be recalculated to present values using an appropriate interest rate.

9 SUBSTATION DESIGN

According to the regulations of the Brazilian electricity sector, and the procedures of the National Electric System Operator (ONS), some prerequisites must be met by air insulation substations (AIS) that operate with bus voltages from 230 kV.

Two types of conditions can apply Basic Conditions and Special Conditions. (Submodule 2.3 – Minimum Requirements for Substations and their Equipment) [15].

The basic conditions are considered as given below, separated by voltage class:

- Buses with voltages of 230 kV: double bar arrangement to four keys, with single circuit breaker;
- Buses of voltage equal to or greater than 345 kV: double bar arrangement with circuit breaker and medium.

These would be the conditions usually implemented for Brazilian high-voltage SEs, connected to the National Interconnected System (SIN) through the Basic Network [15].

In addition to the conventional arrangements listed above, there are special SE arrangement conditions that can be deployed at the expense of conventional topologies, provided that reliability prerequisites are proven by the electric utility.

- Alternative bus arrangements can be used, including those with SF6 isolation technology, provided that they are proven to have performance equal to or superior to conventional topologies. For this to occur, studies of reliability, operational flexibility, and availability must be presented. In addition, the aforementioned arrangements may not compromise the performance of the Basic Network, or cause restrictions to the facilities connected to its buses, and must also be submitted for the approval of the ONS, which analyzes and forwards the treatment proposal to the National Electric Energy Agency (ANEEL)
- For 230 kV buses, the use of main bar arrangement and transfer is allowed, provided that the installation is already designed for an evolution of the four-key double bar arrangement [16].

Given the above, it can be considered that the regulation of the Brazilian Electric Sector allows the application of unconventional arrangements in SE, opening the possibility of using more modern equipment, provided that they present a good operational performance. In this context, there may be the possibility of using hybrid equipment in non-conventional SEs, provided that they meet the minimum requirements specified above that enable new solutions for electromechanical arrangements.

10 UNIFILAR DIAGRAMS

10.1 DIFFERENT SE CONFIGURATIONS

In the design phase of a new SE, several considerations must be raised to define the most appropriate and feasible configuration for a given operation. For example, during the preparation of the unifying diagrams, all factors that may influence or alter the expected results of the SE should be considered, thus ensuring that they do not compromise its main objective of assisting the final decision.

10.2 SINGLE CB SETTINGS

SE designed with only a single CB and multiple DS are considered SE with a focus on maintenance. The common fact is that CBs and sometimes DS can be easily isolated without affecting the flow of energy on the bus.

10.3 DUAL CB SETTINGS

SE with the load connected to two CB is considered SE with a focus on failure and maintenance. This is the reason why these types of configurations are most commonly used in broadcast networks and industries with very high availability and reliability requirements.

10.4 NEW POSSIBILITIES WITH DCB

As mentioned in item V – Availability and Reliability, the CB to SF6 offers better maintenance and failure performance than the DS. This means that the traditional way of building SE with many bus and DS systems decreases availability rather than increasing it. Considering only the above, the best way to increase availability is to eliminate all DS and use only CB. However, due to safety aspects, its disconnect function is required, which makes the DCB necessary equipment to design SE without DS.

11 BASIC NETWORK SETTINGS

11.1 MAIN AND TRANSFER BUS

In the main bus and transfer bus configuration, the circuits remain connected as in the single-bus configuration. During CB maintenance, the bus interconnects CB is used with the line CB of the circuit on which CB maintenance is performed.

- Conventional:
- The main and transfer bus arrangement (Fig. 12) adds a transfer bus to the simple bus arrangement. It also has an interconnection circuit breaker. When a circuit breaker is taken out of service, the interconnecting circuit breaker is used to keep the circuit energized. DS operation is difficult and can lead to operation errors. The degree of reliability and flexibility of this arrangement is not very high, but due to its relatively low cost, this arrangement is widely used in Brazil.

Fig. 12 - Main and transfer bus arrangement

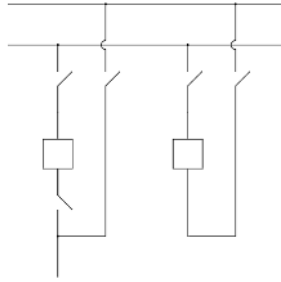

- Circuit breaker disconnecter:

The solution with DCB and a transfer bus is not applicable. Instead, we recommend that you use a main bus or a DCB-sectioned main bus to improve SE availability.

11.2 DUAL BUS WITH 1 CB

In the dual bus arrangement with a circuit breaker, the circuits are usually divided between the buses so that the SE is connected with a single-sectioned bus under normal service conditions, although it can operate with all circuits connected on one bus

- Conventional:

- In the dual bus arrangement with a CB (Fig. 13) when maintenance is required on one of the buses, the circuits connected to that bus can be transferred to the other bus. A dual-bus configuration also provides some flexibility in dedicating certain circuits to a specific bus in the SE.

Fig. 13 - Double bus arrangement and 1 circuit breaker

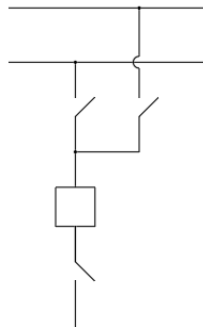

- Circuit breaker disconnecter:

DCB is not applicable in a dual-bus array solution with a circuit breaker, because this configuration is DS-based to transfer circuits between buses at a relatively reduced cost.

11.3 RING BUS

In a bus ring configuration (Fig. 14), all circuits are connected through two CB at the same time. All connected circuits share their two CBs with two other circuits connected in the SE. It is recommended to switch transformer and line connections so that a single fault does not risk affecting two transformers at the same time.

- Conventional: Maintaining the
- CB in this configuration does not affect the connected object. However, maintaining the DS adjacent to the object, which occurs approximately every three to six years, will require the object to be taken out of service.

Fig. 14 Ring bus arrangement

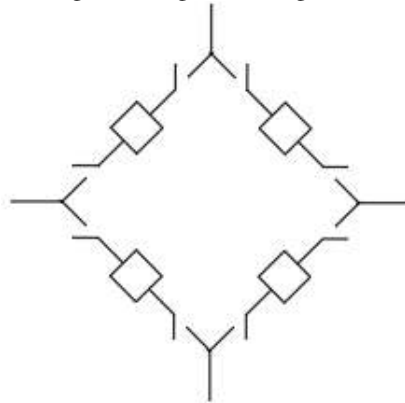

- Disconnecting circuit breakers:

In this arrangement (Fig. 15) the circuit connection interruptions decrease, because the maintenance interval of the DCB is fifteen years, instead of every three to six years as in the DS.

Fig. 15 - Ring bus arrangement with DCB

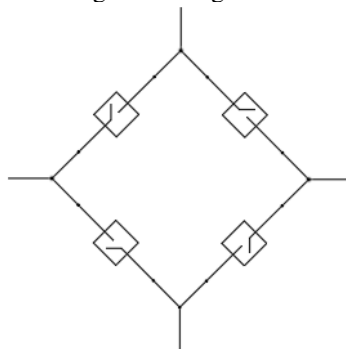

11.4 CIRCUIT BREAKER ARRANGEMENT AND MEDIUM

In the circuit breaker and medium arrangement (Fig. 16), each connected object is connected to a bus via a circuit breaker and shares a circuit breaker with another object that is also connected to a second bus. The circuit breaker and medium configurations provide very good availability.

- Conventional:

- Any of the buses can be taken out of service, without losing any circuit. With sources connected as opposed to loads, it is possible to operate with both buses off. Maintaining the circuit breakers in this configuration does not affect the connected object. However, maintaining the disconnectors adjacent to the object which occurs approximately every three to six years will require the object to be taken out of service.

Fig. 16 - Circuit breaker arrangement and medium

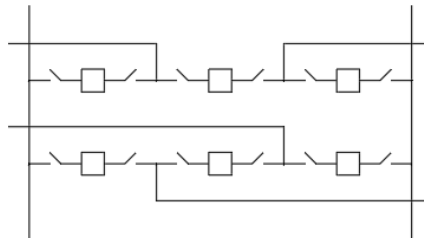

- Circuit breaker disconnecter:

When the DS is removed (Fig. 17), the SE yard with a circuit breaker arrangement and a half require only 60% of the space of the conventional SE yard with the DS. Interruptions in connected circuits decrease, as the maintenance interval of DCBs, is fifteen years instead of every three to six years, as nas DS.

Fig. 17 Circuit breaker arrangement and medium with DCB

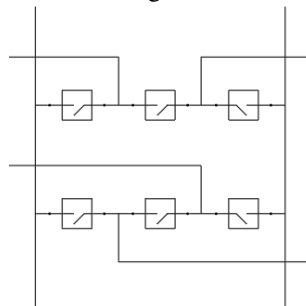

To facilitate the recognition of the application of DCBs for the various types of arrangements, considering a simple replacement of equipment without introducing additional resources to the SE's

bus schemes, Tabela II, presents a summary of the application of DCB and conventional CB in the main bus arrangements.

Table II – Resumo of the application of circuit breakers

ARRAJOS BELONGING TO 'BASIC NETWORK	CONVENTIONAL CIRCUIT BREAKER	CIRCUIT BREAKER DISCONNECTOR (DCB)
<i>Main Bar and Transfer</i>	<i>Applicable</i>	<i>Not applicable</i>
<i>Double Bar with 1 Circuit Breaker to 4 or 5 Keys</i>	<i>Applicable</i>	<i>Not applicable</i>
<i>Ring</i>	<i>Applicable</i>	<i>Applicable</i>
<i>Circuit Breaker and Medium</i>	<i>Applicable</i>	<i>Applicable</i>

Source: authors

12 CONCLUSION

Based on the bibliographic research carried out it was verified that with the technological evolution that provided the emergence of the DCB, there was a significant increase in the availability of energy in the SEs that operate in high and extra high voltage, as well as a reduction considered in the hours destined to the maintenance and, consequently, in the costs throughout the life cycle of the SE that use these types of devices.

The reduction of the space required for the construction of SE, with the use of DCB, was also a point observed and, in some cases, reached 75%.

However, as confronted with some main arrangements of the basic network, it was found that its simple application may not become feasible, leaving its use limited to some configurations. In the Brazilian electrical system, the arrangements of the substations of the basic network in 230 kV, for example, start from the double bar type arrangement at four chaves, a topology that is strongly dependent on the use of DS and that does not adequately apply the DCB with a single bar. Of course, if some features are added to the DCB arrangements, operational advantages can be achieved in terms of increased reliability and reduced maintenance.

The use of new equipment technologies in the Brazilian electrical system, which provides new possibilities for the arrangement of substation yards, linked to space reduction among other advantages, still requires the development of more studies with the involvement of ANEEL, electric power concessionaires, and other agents of the electric sector.

REFERENCES

Disconnecting circuit breakers buyer's and application guide, 2012, abb, high voltage products se-771 80 ludvika, sweden, e-mail: circuit.breaker@se.abb.com

Disconnecting circuit breakers, application guide, 2013. Abb ab, high voltage products, se-771 80 ludvika, sweden, e-mail: circuit.breaker-sales@se.abb.com, www.abb.com/highvoltage.

Tarrago, r. A. Confiabilidade de subestações de transmissão de energia elétrica com aplicação de equipamentos de manobra não convencionais in: dissertação de mestrado, universidade federal do rio grande do sul (ufrgs), escola de engenharia, porto alegre, 2019.

Kezunovic, m. Ghavami, m. Guo, c. Guan, k. Y.g. dam, l. The 21st century substation design final project report: power systems engineering research center empowering minds to engineer the future electric energy system, 2010, arizona state university.

Iec 62271. Part 1: common specifications for alternating current switchgear and control gear, 2017.

Iec 62271. Part 100: alternating-current circuit-breakers, 2012.

Iec 62271. Part 102: alternating current disconnectors and earthing switches, 2013.

Iec 62271. Part 108: high-voltage alternating current disconnecting circuit-breakers for rated voltages of 72,5 kv and above. 2005.

Iec 61936. Power installation exceeding 1kv ac - part 1: common rules. Iec 61936-1 2010.

Sölver, c. E. Et al. Environmental benefits of ais substations with disconnecting circuit-breakers. Paris: cigré, 2008. Report b3-204.

Sweden, l. Olovsson, h.e. abb substations, sweden, v. Disconnecting circuit breaker maximum availability with minimum footprint, 2013, abb, high voltage products se-771 80, e-mail: hans-erik.olvsson@se.abb.com e circuit.breaker@se.abb.com

Sweden, l. Live tank circuit breakers buyer's guide - section ltb family, 2014, abb, high voltage products se-771 80, e-mail: circuit.breaker-sales@se.abb.com.

High voltage circuit breakers: trends and recent developments, 2011, siemens ag, power transmission division high voltage products, e-mail: support.energy@siemens.com.

Especificaciones técnicas de interruptores seccionadores de 72,5 a 800 kv de acuerdo con la comisión electrotécnica internacional (cei), 2015.

Operador nacional do sistema elétrico (ons). Procedimentos de rede, submódulo 2.3, requisitos mínimos para subestações e seus equipamentos. Brasília, 2020. Rev. 2020.06.

Manual de procedimentos da operação - módulo 10 - submódulo 10.22, definição da rede a que pertencem os equipamentos de uma instalação do sin, 2019.