

Development of a prototype of a low-cost sound intensity probe



<https://doi.org/10.56238/Connexpemultidisdevolpfut-021>

Daniel Henrique N. Peixoto

MSc., Department of Structural Engineering - UFMG

Max de Castro Magalhães

PhD, Department of Structural Engineering - UFMG

Guilherme de Souza Papini

DSc., Department of Mechanical Engineering - UFMG

ABSTRACT

The sound intensity is a vector quantity equal to the product of the sound pressure by the particle velocity vector, being used, mainly, for identification and characterization of sound sources. The sound intensity probes called "p-p" use

two pressure transducers, installed very close to each other, to obtain the particle velocity by employing a finite difference approximation to the local spatial gradient of sound pressure. This work has as its main objective to present a low-cost p-p sound intensity probe prototype, built with 3D printing aid and measuring equipment available at UFMG: two preamplified microphones and an acquisition board. MATLAB software was also used, in which a signal processing was implemented to correct the phase difference between the acquisition channels and to calculate the sound intensity. All experiments performed with the intention of validating the sound intensity probe prototype are also presented together with their results, which were quite consistent with the theory studied.

Keywords: Sound intensity probe, Low-cost, Sound intensity.

1 INTRODUCTION

The work "The theory of sound" carried out by Rayleigh in 1877-1878 is considered by many to be the most influential in the study of sound theory, and the quantity he called sound intensity was of great importance [1]. The prominence of this physical quantity in the theory generated the search for an equipment capable of measuring it experimentally. Only in the 1970s was it possible to achieve this goal, in which the first sound intensity probes were built that use two microphones allocated close to each other (type 'p-p').

In the 1980s, p-p sound intensity probes began to be commercialized. Manufacturers took an active part in improvements, mainly in the configurations of sound pressure transducers and in the development of a standard for the construction of the equipment [2]. Currently, the p-p probe can already be considered a mature technology, however, although it has already been consolidated and has several important applications, in Brazil, the price of these equipment restricts its use. It aims to contribute to a change in this reality, developing a low-cost sound intensity probe that makes this technology more accessible, capable of meeting some applications in which a commercial probe would be needed and, most importantly, capable of being reproduced and improved in a free way.



This article presents the initial phase of the development of a low-cost p-p sound intensity probe, which aimed to: test the computationally implemented signal processing; consolidate and put into practice theoretical concepts through experimental trials; build a first base structure to position the microphones. Parts made by a 3D printer, a data acquisition board and two preamplified microphones were used. The implementation of digital signal processing was done in MATLAB.

2 DEVELOPMENT

2.1 THEORETICAL BASIS

2.1.1 Sound intensity

Sound intensity (I) is the rate of sound energy flow that crosses a normal unit area at the direction of propagation [3]. The instantaneous value of the sound intensity $I_n(t)$ in the direction of the unit vector \vec{n} is the product of the sound pressure $p(t)$ by the particle velocity $u_n(t)$:

$$I_n(t) = p(t)u_n(t). \quad (1)$$

In practice, it is more concerned with stationary sound fields and with the temporal average of the sound intensity, shown by Eq.2, than with the instantaneous sound intensity [6].

$$\langle I_n(t) \rangle_t = \langle p(t)u_n(t) \rangle_t \quad (2)$$

In the specific case of "purely" progressive plane waves, that is, without reflection, considering a single frequency, the average sound intensity is represented by Eq. 3, where A is the amplitude of the wave, ρ_0 the density of the air and c the speed of sound.

$$\langle \vec{I}(t) \rangle_t = (1/2)(A^2/\rho_0 c) \quad (3)$$

2.1.2 Sound intensity probe: measuring principle p-p

The p-p method determines the particle velocity through an approximation of the pressure gradient by finite difference using two microphones allocated very close to each other and uses the average of the microphones as sound pressure. Starting from these two approximations, Frank Fahy [2] deduces, from the *momentum* equation and the mass conservation equation, the average sound intensity measured from two microphones in the time domain (Eq. 4).

$$I_n = \left(\frac{1}{\rho_0 d} \right) \lim_{T \rightarrow \infty} \left(\frac{1}{T} \right) \int_0^T \left[p_1(t) \int_{-\infty}^t p_2(\tau) d\tau \right] dt \quad (4)$$

The mean sound intensity formula in the frequency domain is given by Eq. 5.

$$I_r(\omega) = \left(\frac{1}{\rho_0 \omega d} \right) \text{Im}\{G_{p_2 p_1}(\omega)\} \quad (5)$$



2.1.3 Phase-mismatch error in p-p probes

Jacobsen [4] states that the most important limitations of the p-p probe are caused: i) by the approximation of the finite difference; ii) by diffraction and sound dispersion; (iii) the phase difference between the acquisition channels.

The *phase-mismatch* between the acquisition channels of a probe is the most worrisome source of error in the measurement of sound intensity, even with the best equipment available today [5]. In the low frequency range is where this type of error is most critical, because in it the same error is proportionally greater. There are two most commonly used ways to evaluate *phase-mismatch*. The first is through the Residual Pressure-Intensity Coefficient (CPIR), which is obtained when the two microphones are exposed to the same sound pressure in a controlled acoustic field. In this specific situation, the Pressure-Intensity Coefficient δ_{pI} , presented by Eq. 6, becomes the Residual Pressure-Intensity Coefficient: $\delta_{pI} \rightarrow \delta_{pI0}$. In the equation below L_p is the sound pressure level measured by the microphones and $L_{|I_i|}$ the sound intensity level. The other way to assess the phase difference between two signals is through cross-spectrum data.

$$\delta_{pI} = L_p - L_{|I_i|} [dB] \quad (6)$$

2.2 EXPERIMENTS

2.2.1 Experiment 1

The essay presented in this section aims to test the implementation of the *phase-mismatch* error correction method created by Krishnappa [6]. It consists of exposing two microphones to the same sound pressure, so that, with the use of a transfer function, the response properties of one of the microphones are passed to the other.

The proposed experiment uses a 378B20 microphone from PCB Piezotronics (Mic 1) and an MPA201 microphone from BSWA Tech (Mic 2), the NI 9234 acquisition board, parts made by 3D printing, speaker with *bluetooth*, wood parts and PVC pipe of nominal diameter of 75 [mm]. The 3D printing piece has the function of positioning the microphones so that the axis that connects their central points is perpendicular to the propagation of sound waves inside the tube (Fig. 1.a). The spacing between the microphones is 28 [mm]. Fig. 1 shows a sequential step-by-step of the experimental plant assembly, starting with Fig. 1.a and ending at Fig. 1.f. To complete the assembly, the microphones must be connected via BNC cables to the NI 9234 board, which in turn is connected to a microcomputer.

In this test, a calibration measurement is performed, in which the responses of the two microphones are compared in relation to amplitude and phase. With the signals obtained in the calibration, the transfer function capable of equalizing the responses of the two microphones is



calculated, so that in a second measurement this function is applied to one of the two. Thus, after applying the correction, one can again compare the responses of the two microphones and examine whether the differences have been corrected.

Each experimental measurement involves the following steps: 1) assembling the experimental plant as shown in Fig. 1; 2) connect the microphones to the acquisition board and the same to a microcomputer; 3) send a pink noise signal to the speaker via *bluetooth*; 4) perform the capture of the calibration measurement; 5) perform a second measurement, using the same pink noise signal, in which the obtained variables are corrected.

Figure 1. Illustration of a step-by-step for assembling the experiment. In the figures e) and f) The barrel was represented in a transparent manner. In green is the piece printed and in blue was represented the speaker.

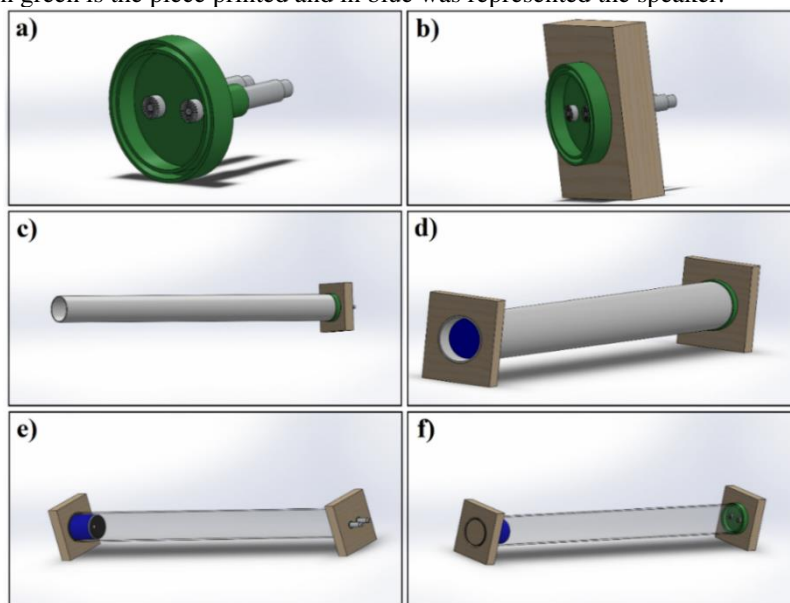

2.2.2 Experiment 2

In the specific case of progressive plane waves, it is possible to obtain the value of sound intensity from sound pressure through a method that is based on the implementation of Eq. 3. By convention this method is now called the Analytical Method. The method that consists of implementing the p-p measurement principle represented by Eq. 5 and which is the basis of the sound intensity probe developed, is called, by convention, the p-p Method.

This section is intended to present an experiment in which it is aimed at reproducing a sound field of progressive plane waves to then compare the values of sound intensity obtained with the Analytical Methods and p-p. What differs the two methods is that the so-called Analytical Method works only for "purely" progressive flat sound waves and, in these circumstances, is accurate, whereas the method used in the p-p probe was developed to measure sound intensity in various types of acoustic fields. The idea is to put the p-p Method to the test by comparing it with the Analytical Method in the



case of flat and progressive waves so that later the p-p Method can be used in other less restricted acoustic environments.

In this test, the plant of Fig. 1 and the assembly shown by Fig. 2 are used. Fig. 2.a shows the plant as a whole and Fig. 2.b and 2.c show details of parts of the assembly. The new plant comprises: a PVC pipe 6 [meters] long and nominal diameter of 75 [mm], a 3D printing piece, two microphones, rock wool, polyurethane acoustic foam, wooden bases and a bluetooth speaker. The 3D printing piece, shown in green color by Fig. 2, has the function of positioning the microphones in parallel with the propagation of sound waves, in addition to maintaining a fixed spacing of 20 [mm] between the microphones.

At the end of the tube, absorbent materials were placed to make the tip opposite the speaker an anechoic termination. This measure aims to reduce sound reflection to the maximum so that the Analytical Method works correctly. In addition, the choice of a large length tube and the positioning of the microphone very close to the speaker (50 [cm]) also help to increase the effectiveness of the experiment.

Figure 2: Plant of the experiment that aims to create a field of "purely" progressive plane waves.

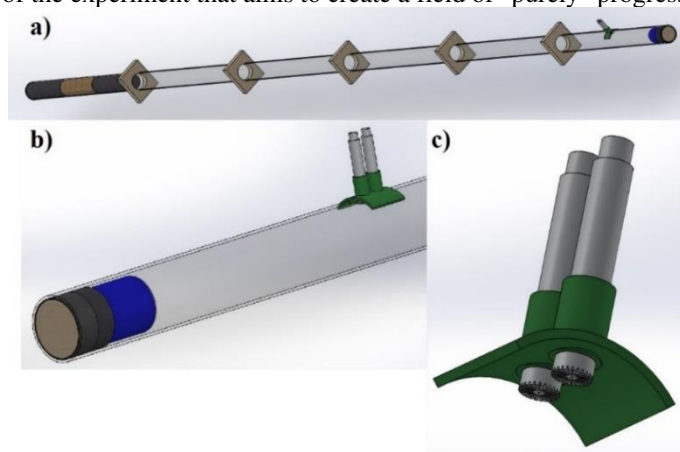

The experiment begins by using the blueprint in Fig. 1 to perform a calibration measurement, which is the same as in Experiment 1. Then the two microphones are placed in the plan presented by Fig. 2. In the execution of the measurements it is possible to use the same five steps of the previous experiment with modifications in the fifth step. The first change is that before the second measurement was performed on the Fig. 1 plant, now it is done on the Fig. 2 plant. The second is that, although pink noise is maintained in the calibration measurement (first measurement), in the sound intensity measurement (second measurement) other sound signals are used in addition to pink noise.



2.2.3 Probe prototype support structure

In addition to testing the computationally implemented signal processing and consolidating the theoretical concepts through experimental tests, the elaboration of a basic structure to position the microphones began. This base frame, easy to reproduce since it is enough to have access to a 3D printer to materialize it, will be used in the next steps of the research for testing the prototype in acoustically less restricted environments, in addition, this first model will serve as a starting point for new improved versions of the probe structure.

Among the most common configurations for p-p probes, the only ones that have geometric compatibility with the microphones used in this research are: *face-to-face* and *side-by-side*. At the present stage of the research it is believed that the best option is the *side-by-side* configuration, because, within the frequency range so far investigated, the main errors that affect sound intensity measurements with p-p probes are low and known for this arrangement.

In this first prototype we tried to facilitate the change of distance between the microphones (Δ), in order to control the errors caused by the approximation of the finite difference and the *dphase-mismatch*. A fitting structure was made, in which the part that defines can be easily exchanged. Fig. 3 shows the parts made by 3D printing next to the drawings in *dSolidWorks*.

Figure 3: Parts materialized by 3D printing next to the drawings made in *SolidWorks*. *Side-by-side*.

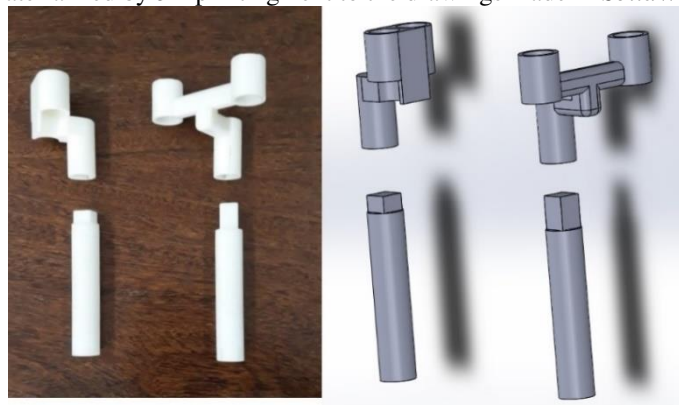
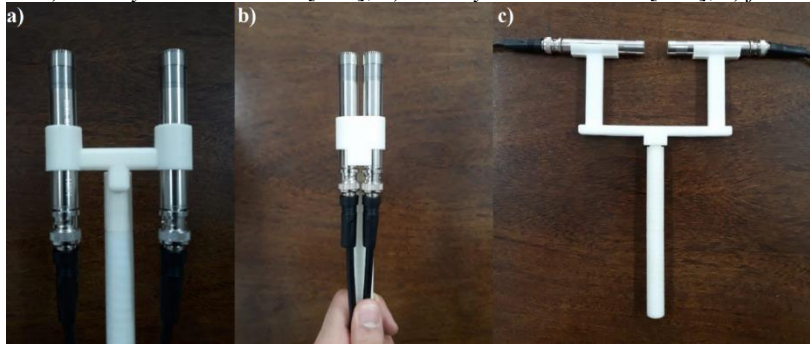

Fig. 4 shows photos of the prototype probe already assembled and with the microphones positioned. Fig. 4.a and 4.b show the *side-by-side* arrangement with distances of 50 and 15 [mm], respectively. Fig. 4.c shows the prototype with the *face-to-face* configuration, which although deprecated at first, may be used later.



Figure 4: a) *side-by-side* as $d = 50$ [mm]; b) *side-by-side* as $d = 15$ [mm]; c) *face-to-face*.



3 RESULTS AND DISCUSSIONS

3.1 RESULTS OF EXPERIMENT 1

Twenty trials of Experiment 1 were divided into two groups of ten, carried out on two different days: day 1 and day 2. The first result to be analyzed concerns the sound pressure levels (SPL) measured in the two channels in a calibration measurement. Fig. 5 shows in blue the values of SPL measured by Mic 1 and red values measured by Mic 2, and this result is very similar in all twenty measurements. For the value of the internal diameter of the tube used, we have a cut-off frequency of approximately 2765 [Hz]. This expected value is confirmed by the graph in Fig. 5, in which the responses are practically superimposed until the calculated cutoff frequency, in which they begin to diverge. The premise that the calibration plant subjects the two microphones to the same sound pressure, provided that the range below the cutoff frequency is considered, is proven.

Figure 5: NPS's values measured by the two acquisition channels before correction.

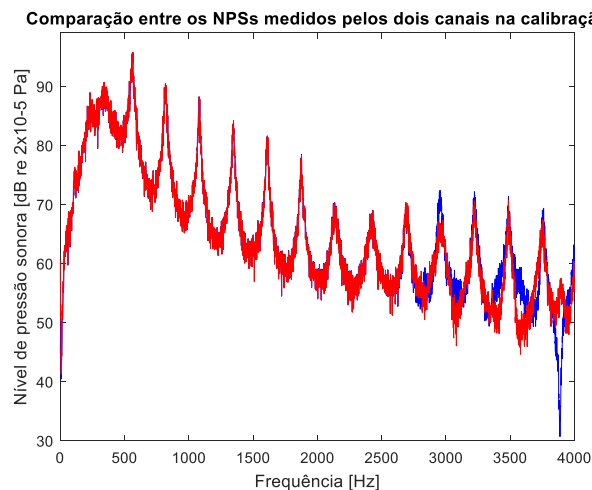

After performing the measurement after the calibration measurement, in which the corrections were applied to the Mic 2 response, it is possible to compare the absolute mean difference of SPL between the two microphones before and after the correction. Table 4.1 summarizes the results



obtained, and the values show that the correction of the answers, with regard to magnitude, was effective.

Table 1: The mean absolute difference in [dB] between the measured SPL's: before and after correction.

Day 1			Day 2		
Measurement	Mean Difference [dB]		Measurement	Mean Difference [dB]	
	Uncorrected	With correction		Uncorrected	With correction
1	0,28129	-0,001729	1	-0,013365	-0,001175
2	0,26167	0,001457	2	-0,017798	-0,001432
3	0,258325	-0,000451	3	-0,018546	0,000391
4	0,260497	-0,000912	4	-0,020473	0,000369
5	0,2564	0,001237	5	-0,021349	0,00073
6	0,260445	-0,002063	6	-0,021839	-0,005079
7	0,256784	0,000102	7	-0,029188	0,004166
8	0,25459	0,001438	8	-0,025681	-0,001423
9	0,254656	0,00283	9	-0,026856	-0,001827
10	0,253372	-0,000172	10	-0,026108	-0,003386

Figure 6: Comparison of phase-mismatch before and after correction.

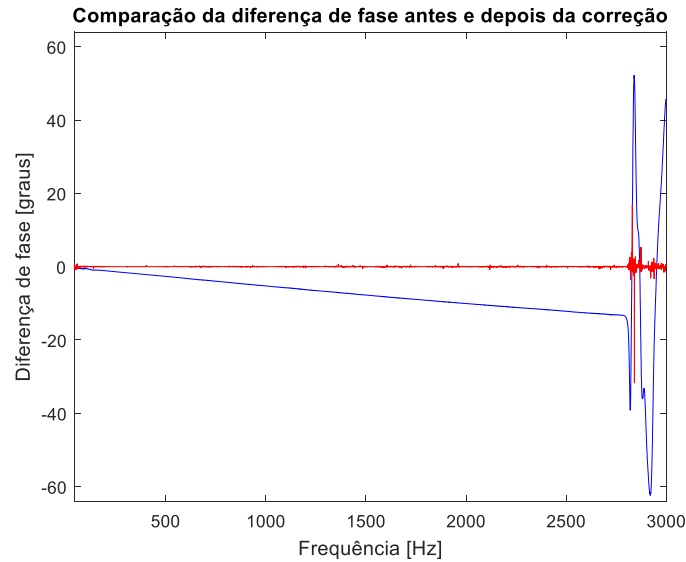

Fig 6 shows the phase difference obtained from the cross-power spectral density data of one of the measurements, comparing the results before (blue) and after (red) the correction. It is verified that the correction made was effective, because it decreased the phase difference between the signals. The behavior of the phase differences, before and after correction, shown in Fig. 6 was very similar in all twenty measurements.

Another way to analyze the phase difference is through the residual pressure-intensity coefficient (CPIR), using the values suggested by IEC 1043 for class 2 and class 1 instruments as references. Fig. 7 summarizes the results found. For the measurement in question, after correction, all bands have values higher than those recommended for class 1, and before correction all bands had



values below those recommended for class 2 instruments. The behavior of the twenty measurements, summarized below, prove, once again, the efficiency of the correction method applied:

- Before correction: all bands of all measurements were below class 2;
- After correction: all bands of all measurements started to have values above those recommended for class 2. All bands above 100 [Hz] of all measurements started to have values above those recommended for class 1. For bands below 100 [Hz] it was common for one or two bands, by measurement, to fall below class 1.

Figure 7: Comparative graph with CPIR values.

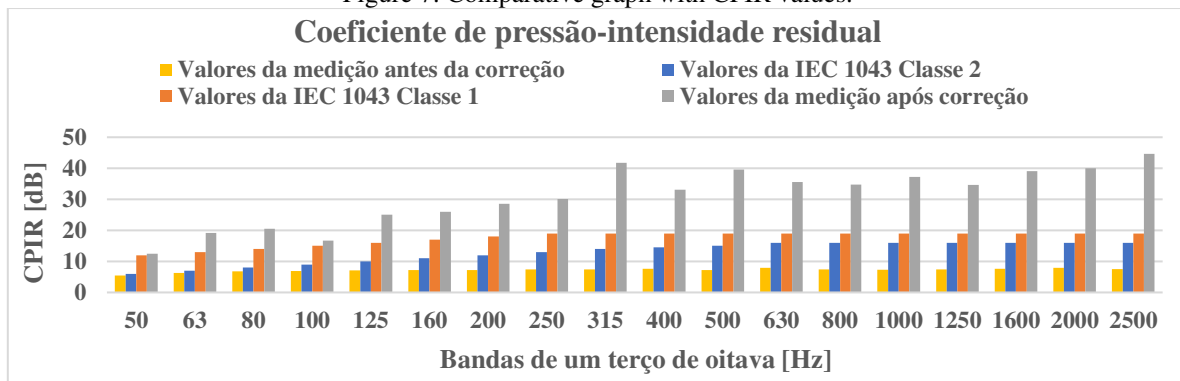

3.2 RESULTS OF EXPERIMENT 2

Pink noise was maintained as a signal to be reproduced on the speaker in the calibration measurement, but for the measurement of sound intensity in the Fig. 2 plant, four other signals were used in addition to pink noise: white noise, a tonal signal of 1000 [Hz] and two noises from industrial machinery (recordings). The use of signals other than pink noise occurs to test whether the calibration works for any type of sound signal to be measured later.

The result to be analyzed for this experiment is the difference between the values of the sound intensity level (NIS) found using the p-p Method, with and without correction, and the Analytical Method. The goal of separating the p-p Method into with and without correction is to test once again the applied correction, now using another experimental plant and other sound excitation signals. For the white noise test, Figs. 8 and 9 show the comparison between the NIS values.



Figure 8: Comparison between NIS's: p-p Method with correction (blue) and Analytical Method (red).

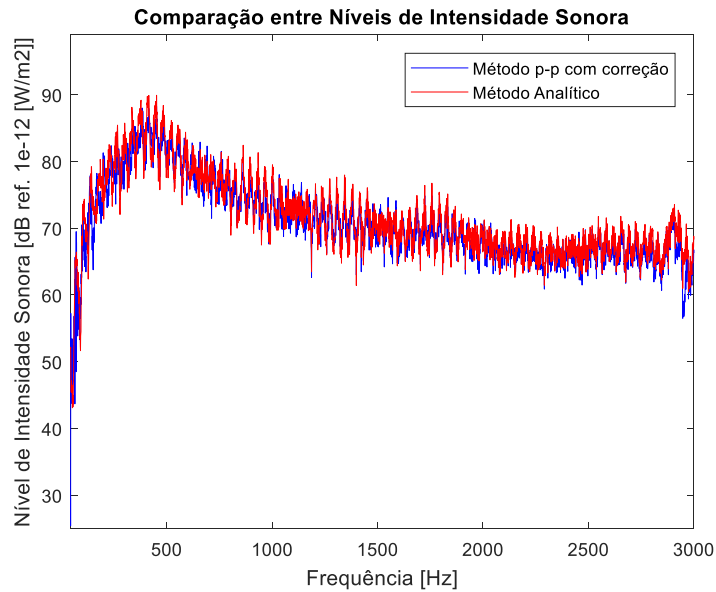
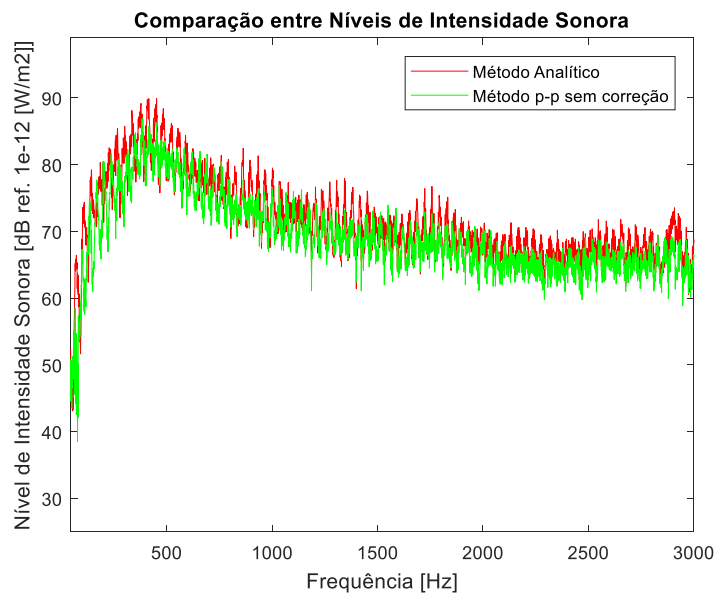

Figure 9: Comparison between NIS's: p-p method without correction (green) and Analytical Method (red).



Graphically, it is observed that the three methods have similar results and behaviors very similar to each other. The same occurred for the other four signals used. It is concluded that: the implementation of the three methods was performed correctly and the signal processing that applies the correction in the phase difference has stability outside the sound field in which the transfer function variables are captured.

Still in the graphical analysis of Figs. 8 and 9, using the Analytical Method as a reference, one has the impression that the p-p Method with correction generated better results than the one without correction. To facilitate this evaluation and present the results as it is done by commercial probes, the values obtained were passed to bands of one third of an octave (Fig. 10). Thus, it was clearer the



improvement of the results achieved using the correction, since the presentation in bands facilitates the perception that the p-p Method with correction produces values closer to those obtained through the Analytical Method than the p-p Method without correction.

Figure 10: Comparison between methods in bands of one third of an octave.

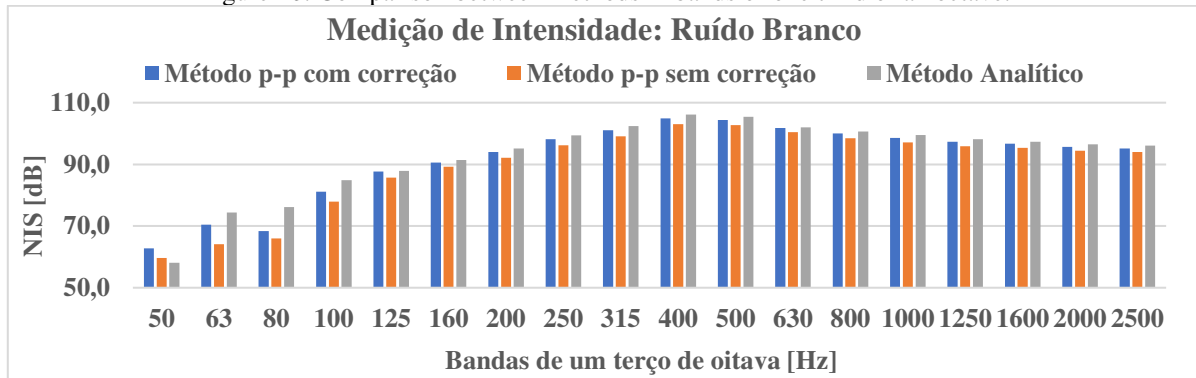

The graphs of the other signals used had behavior very similar to that shown in Fig. 10 in the bands from 125 [Hz], always with the corrected values closer to the Analytical Method. There was a greater disagreement between the results below 100 [Hz], which is expected, because at very low frequencies the anechoic termination made with absorbent materials loses efficiency, therefore, the Analytical Method stops working as a good reference, since the assumption of propagation of progressive waves without reflection is no longer valid. The decrease in the error in the results due to correction was general for all five excitation signals used, of the seventy bands of one third of octaves analyzed - fourteen bands (125 to 2500 [Hz]) of five signals - only in two the error increased with the correction, and in both errors of the corrected results did not exceed 1 [dB].

4 CONCLUSIONS

This article presents the experiments that are part of the initial phase of the development of a low-cost sound intensity probe. The results give strong indications that the signal processing in MATLAB together with the equipment used provide pertinent values of sound intensity. The correction of the phase difference between the acquisition channels was also tested and approved. A first version of a base structure for positioning microphones in sound intensity measurements was presented. With the results of this work, the research will continue: an interface for the signal processing program will be developed, the design for the probe will be improved and tests will be carried out to compare the prototype with a calibrated commercial probe.



REFERENCES

BRÜEL & KJÆR PUBLICATION. *Sound Intensity*. Nærum, Denmark, 1993.

FAHY, F. J. *Sound Intensity*. 2^a ed. London: E & FN Spon, 1995.

KINSLER, L. E.; FREY, R. A.; COPPENS, A. B.; SANDERS, J.V. *Fundamentals of Acoustics*. 4^a ed. John Wiley & Sons, Inc. 2000.

JACOBSEN, F. *Sound Intensity*. Capítulo 25 em *Springer Handbook of Acoustics*, ed. Thomas Rossing. Springer Verlag, New York, 2007.

JACOBSEN, F. *Sound Intensity and Its Measurement and Applications*. Denmark: Technical University of Denmark. 2011.

KRISHNAPPA, G. *Cross-spectral method of measuring acoustic intensity by correcting phase and gain mismatch errors by microphone calibration*. *The Journal of the Acoustical Society of America*. 69, 307 (1981);